



YEKTA TAHVIEH
Arvand



ASGHARIAN
HOLDING

Ducted Fan Coils Unit

From 1020 to 3400 m³/hr

Exposed & Furred – in Ceiling Models



YEKTA TAHVIEH
ARVAND
www.arvandcorp.com

Table of Contents

Model Number Nomenclature	1
Introduction	2
Features / Benefits	2
The ADF Series	3
Options (Factory installed)	4
Physical Data	4
Capacity Data	5
Performance Data	13
Dimension	16
Engineering guide Specification	20

Model number nomenclature

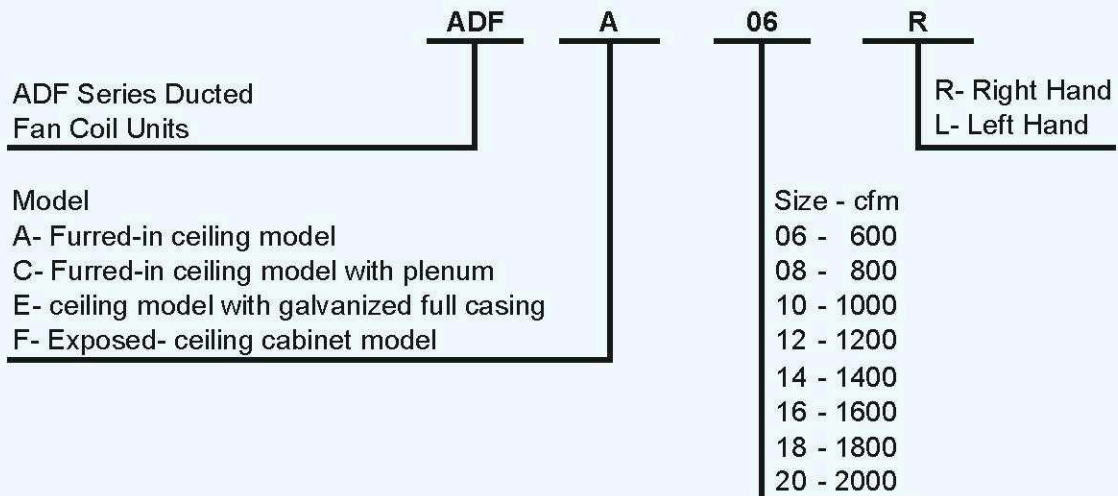

Ducted Fancoil Air Conditioners 1020-3400 m³/hr

Product Data

ARVAND ADF series ducted fan coil units offer design and equipment location flexibility.

- Choice of 4 models , each available in 8 sizes
- For - 2 - pipe 4 -pipe and electric heat systems with optional factory furnished controls.
- Up to 0.4 inwg duct static with some models.

Features / Benefits

The ADF series ducted fan coil unit delivers quiet, dependable air conditioning in a wide range of capacities Units providing air flow of 1020 to 3400 m³/hr (600 to 2000 cfm) are designed to economically fill multiroom application requirements in apartments, motels, and office buildings.

These easy - to - install units are available in horizontal models for cabinet or furred - in applications. Casings and frame are fabricated from tough , heavy gage galvanized steel models ADFA , FC and FE feature a galvanized finish as standard The FF cabinet has a recoatable baked finished.

A wide variety of factory - installed options

(including coil, motors, filters, drain pans and electric strip heaters) can custom - tailor your units to the exact conditions of your applications.

Low - cost installation

Each unit is designed to occupy a minimum space. This feature along with convenient wiring and piping connections means the ADF reduces costs on renovations or new construction sites Grommeted mounting holes or slots on top of the unit speed hanging Quiet.

dependable performance

All ADF series unit are built to operate unobtrusively, with quiet motors and a low fan speed. Plastophom 20 mm. thick, absorbs operating sound in the fully insulated casings.

Efficient operation

ADF quality reduces service and maintenance expenses. Condensate drain pan is stainless steel so corrosion is omitted and long , trouble - free life is assured .

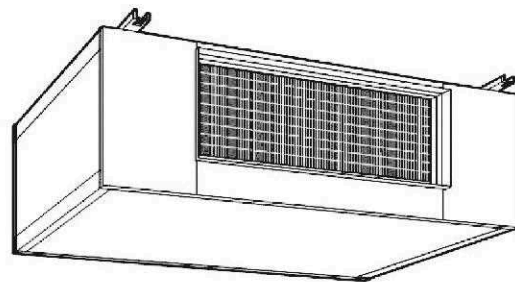
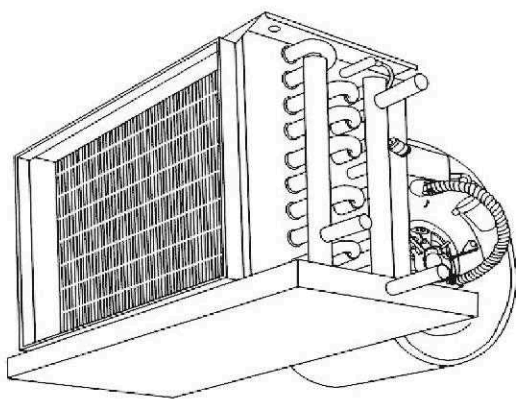

The ADF series

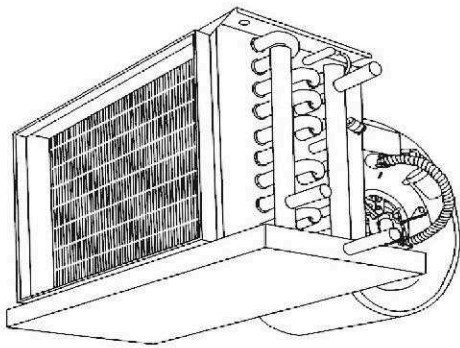

ADFA

Furred - in ceiling model for installation in the ceiling or over the closet.

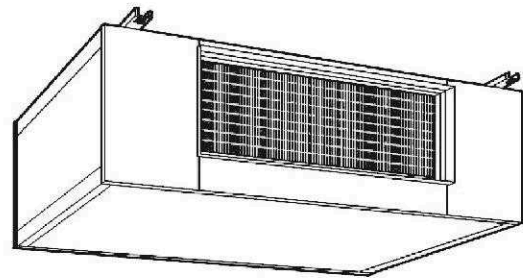

ADFE

Ceiling model with galvanized casing.

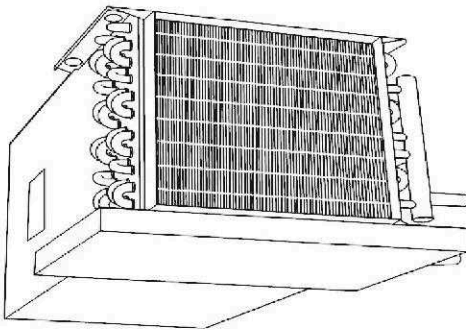

ADFC

Furred - in ceiling model with factory - installed insulated plenum.

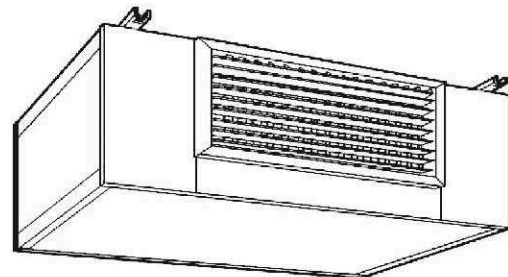

ADFF

Exposed - ceiling cabinet model with integral double - deflection discharge grille and a bar - type return - air grille.

Options (Factory - installed)

Coils - Choice of 2 - pipe system with 4 - or 6 - row cooling and heating coils, or 4 - pipe system with 4 - or 6 - row cooling coils and one - or 2 - row heating coils. Six-in. diameter outside air opening with duct collar and filter to duct outside ventilation air damper. (Available on model FC, FE and FF.)

Filters - Cleanable one-in thick glass fiber filter available for FC and FE .(Aluminum washable filter is standard on these units.)

Physical Data

Cooling:

Entering Air Temp. : 27/19 °C (DB/WB)
Entering/Leaving Water Temp. : 7/12 °C

Heating:

Entering Air Temp. : 20 °C
Entering/Leaving Water Temp. : 80/70 °C

ADF MODEL		06	08	10	12	14	16	18	20
Heating & Cooling Coil	Face Area (m ²)	0.13	0.17	0.2	0.24	0.28	0.33	0.37	0.40
	Air Flow (m ³ /hr)	1020	1360	1700	2040	2380	2720	3060	3400
	Row * Fin/inch	4 * 8	4 * 8	4 * 8	4 * 8	4 * 8	4 * 8	4 * 8	4 * 8
	Cooling Capacity (1000Kcal/hr)	4.23	4.8	6.47	8.32	10.14	10.94	11.17	12.83
	Max Water Flow (L/hr) (Cooling)	740	960	1290	1660	2025	1850	2230	2560
	Heating Capacity (1000Kcal/hr)	12.74	16.91	21.53	26.05	30.59	35.12	39.66	43.97
	Max Water Flow (L/hr) (Heating)	1270	1690	2150	2600	3055	3505	3960	4390
	Cooling Max Pressure Drop (mH ₂ O)	0.38	0.40	0.76	1.36	2.17	0.3	0.45	0.62
Fan & Motor	No of fan	1	1	1	1	1	2	2	2
	Max Fan Power	150W	250W	250W	250W	250W	500W	500W	500W
	Max RPM	900	800	800	800	800	800	800	800

COOLING CAPACITY RATINGS FOR ADF SERIES

Entering Water Temperature 5 °C, differential temperature 5 °C (4 ROW COIL)

Model ADF-	Air Flow m ³ /hr	Entering Air DB (°C)	Entering Air WB (°C)											
			17			19			21			23		
			Capacity (1000Kcal/hr)		Water Flow Rate L/hr	Capacity (1000Kcal/hr)		Water Flow Rate L/hr	Capacity (1000Kcal/hr)		Water Flow Rate L/hr	Capacity (1000Kcal/hr)		Water Flow Rate L/hr
			Total	Sensible		Total	Sensible		Total	Sensible		Total	Sensible	
06	1020	25	3.49	2.96	704	4.78	3.05	965	6.21	3.09	1253	7.71	3.06	1557
		27	3.97	3.76	801	4.75	3.45	959	6.18	3.51	1247	7.68	3.50	1551
		30	4.67	4.67	942	4.72	4.04	953	6.14	4.14	1239	7.62	4.15	1539
08	1360	25	4.58	3.90	924	6.21	3.97	1253	8.06	4.02	1627	10.03	3.98	2024
		27	5.21	4.96	1051	6.17	4.50	1245	8.03	4.58	1620	9.98	4.56	2015
		30	6.12	6.12	1236	6.13	5.28	1238	7.97	5.40	1610	9.91	5.41	2000
10	1700	25	5.99	5.03	1209	8.15	5.18	1645	10.40	5.18	2100	12.81	5.08	2585
		27	6.68	6.29	1348	8.11	5.86	1636	10.36	5.89	2092	12.76	5.82	2575
		30	7.79	7.79	1573	8.06	6.87	1627	10.30	6.94	2080	12.67	6.90	2557
12	2040	25	7.75	6.41	1564	10.35	6.51	2089	13.00	6.46	2624	15.89	6.30	3208
		27	8.25	7.67	1666	10.25	7.35	2070	12.95	7.33	2615	15.83	7.22	3196
		30	9.58	9.58	1934	10.21	8.59	2060	12.89	8.62	2601	15.73	8.54	3175
14	2380	25	9.48	7.77	1914	12.45	7.82	2513	15.59	7.73	3147	18.97	7.52	3829
		27	9.82	9.05	1982	12.39	8.83	2502	15.54	8.77	3137	18.91	8.61	3816
		30	11.37	11.37	2294	12.34	10.31	2491	15.46	10.29	3122	18.78	10.17	3791
16	2720	25	–	–	–	12.05	7.75	2432	15.74	7.86	3177	19.64	7.80	3965
		27	10.24	9.81	2067	11.97	8.78	2415	15.67	8.96	3163	19.56	8.94	3948
		30	12.07	12.07	2436	12.09	10.47	2440	15.56	10.58	3141	19.40	10.61	3917
18	3060	25	10.45	8.86	2110	14.25	9.10	2877	18.36	9.15	3705	22.73	9.03	4589
		27	11.84	11.22	2390	14.17	10.30	2859	18.28	10.41	3691	22.64	10.33	4570
		30	13.87	13.87	2801	14.08	12.08	2842	18.17	12.27	3668	22.47	12.26	4537
20	3400	25	11.87	9.99	2395	16.20	10.31	3270	20.71	10.31	4180	25.52	10.13	5152
		27	13.31	12.55	2687	16.11	11.67	3251	20.63	11.73	4164	25.42	11.60	5132
		30	15.55	15.55	3138	16.02	13.67	3233	20.51	13.82	4139	25.24	13.75	5096

COOLING CAPACITY RATINGS FOR ADF VERSION

Entering Water Temperature 7 °C, differential temperature 5 °C (4 ROW COIL)

Model ADF-	Air Flow m ³ /hr	Entering Air DB (°C)	Entering Air WB (°C)											
			17			19			21			23		
			Capacity (1000Kcal/hr)		Water Flow Rate L/hr	Capacity (1000Kcal/hr)		Water Flow Rate L/hr	Capacity (1000Kcal/hr)		Water Flow Rate L/hr	Capacity (1000Kcal/hr)		Water Flow Rate L/hr
			Total	Sensible		Total	Sensible		Total	Sensible		Total	Sensible	
06	1020	25	3.03	2.82	611	3.73	2.52	753	5.20	2.64	1049	6.72	2.66	1356
		27	3.52	3.52	711	3.70	2.89	748	5.17	3.05	1044	6.69	3.08	1350
		30	4.23	4.23	853	4.23	3.90	855	5.14	3.64	1037	6.63	3.70	1339
08	1360	25	—	—	—	4.84	3.29	977	6.74	3.44	1361	8.72	3.45	1760
		27	4.62	4.62	932	4.80	3.77	969	6.71	3.97	1355	8.68	4.01	1753
		30	5.54	5.54	1119	5.55	5.14	1121	6.66	4.74	1345	8.61	4.82	1738
10	1700	25	5.17	4.75	1044	6.52	4.37	1315	11.21	4.44	2262	11.21	4.44	2262
		27	5.95	5.95	1200	6.47	5.01	1306	11.16	5.14	2253	11.16	5.14	2253
		30	7.07	7.07	1428	7.08	6.49	1429	11.08	6.18	2236	11.08	6.18	2236
12	2040	25	6.46	5.85	1303	8.36	5.56	1688	11.07	5.60	2235	13.97	5.53	2819
		27	7.37	7.37	1487	8.32	6.35	1679	11.03	6.44	2227	13.91	6.40	2809
		30	8.71	8.71	1758	8.72	7.90	1760	10.97	7.68	2215	13.82	7.68	2789
14	2380	25	7.72	6.92	1559	10.19	6.72	2057	13.35	6.74	2694	16.73	6.63	3376
		27	8.78	8.78	1773	10.14	7.68	2047	13.30	7.73	2685	16.67	7.65	3365
		30	10.34	10.34	2087	10.36	9.30	2090	13.24	9.21	2672	16.56	9.17	3342
16	2720	25	—	—	—	9.31	6.36	1880	13.12	6.70	2648	17.05	6.75	3441
		27	9.07	9.07	1830	9.23	7.30	1863	13.05	7.74	2635	16.97	7.84	3425
		30	10.92	10.92	2204	10.94	10.18	2208	12.95	9.26	2615	16.82	9.45	3396
18	3060	25	—	—	—	11.25	7.60	2271	15.43	7.86	3115	19.82	7.85	4002
		27	10.52	10.52	2124	11.17	8.71	2255	15.36	9.06	3101	19.74	9.10	3984
		30	12.58	12.58	2538	12.59	11.61	2542	15.26	10.82	3080	19.58	10.95	3953
20	3400	25	10.30	9.48	2080	12.92	8.69	2608	17.48	8.89	3529	22.31	8.83	4504
		27	11.85	11.85	2392	12.83	9.95	2591	17.41	10.24	3515	22.22	10.24	4486
		30	14.10	14.10	2847	14.12	12.96	2851	17.30	12.23	3492	22.05	12.31	4452

COOLING CAPACITY RATINGS FOR ADF VERSION

Entering Water Temperature 10 °C, differential temperature 5 °C (4 ROW COIL)

Model ADF-	Air Flow m ³ /hr	Entering Air DB (°C)	Entering Air WB (°C)											
			17			19			21			23		
			Capacity (1000Kcal/hr)		Water Flow Rate L/hr	Capacity (1000Kcal/hr)		Water Flow Rate L/hr	Capacity (1000Kcal/hr)		Water Flow Rate L/hr	Capacity (1000Kcal/hr)		Water Flow Rate L/hr
			Total	Sensible		Total	Sensible		Total	Sensible		Total	Sensible	
06	1020	25	—	—	—	—	—	—	3.50	1.90	707	5.08	2.02	1026
		27	—	—	—	—	—	—	3.48	2.24	703	5.06	2.41	1021
		30	3.56	3.56	718	3.56	3.56	719	3.57	2.84	720	5.01	2.97	1011
08	1360	25	—	—	—	—	—	—	4.54	2.46	916	6.59	2.62	1330
		27	—	—	—	—	—	—	4.51	2.92	910	6.55	3.12	1322
		30	4.66	4.66	942	4.67	4.67	943	4.68	3.74	944	6.49	3.87	1310
10	1700	25	—	—	—	—	—	—	6.14	3.31	1240	8.60	3.41	1736
		27	4.83	4.83	975	4.84	4.33	976	6.11	3.91	1234	8.56	4.07	1728
		30	5.98	5.98	1207	5.99	5.99	1208	6.07	4.79	1224	8.44	5.03	1703
12	2040	25	5.09	5.09	1028	5.10	3.89	1029	7.92	4.23	1599	10.84	4.30	2189
		27	6.03	6.03	1216	6.03	5.33	1218	7.89	4.99	1592	10.80	5.11	2180
		30	7.39	7.39	1491	7.40	7.40	1493	7.84	6.11	1582	10.71	6.30	2163
14	2380	25	6.13	6.13	1238	6.42	4.83	1297	9.68	5.15	1954	13.09	5.19	2641
		27	7.21	7.21	1456	7.22	6.32	1457	9.64	6.06	1946	13.04	6.15	2632
		30	8.79	8.79	1774	8.80	8.80	1777	9.59	7.41	1936	12.94	7.58	2612
16	2720	25	—	—	—	—	—	—	—	—	—	12.81	5.09	2585
		27	7.27	7.27	1467	7.27	6.65	1468	8.65	5.63	1745	12.74	6.08	2571
		30	9.17	9.17	1852	9.19	9.19	1854	9.20	7.39	1857	12.60	7.54	2544
18	3060	25	—	—	—	—	—	—	10.57	5.72	2135	15.08	5.99	3044
		27	8.50	8.50	1716	8.51	7.69	1718	10.51	6.77	2122	15.00	7.14	3029
		30	10.60	10.60	2140	10.62	10.62	2143	10.63	8.46	2147	14.86	8.84	3000
20	3400	25	—	—	—	—	—	—	12.18	6.56	2458	17.09	6.78	3451
		27	9.62	9.62	1942	9.63	8.64	1944	12.11	7.76	2445	17.01	8.09	3435
		30	11.92	11.92	2406	11.93	11.93	2409	12.02	9.51	2426	16.86	10.00	3404

COOLING CAPACITY RATINGS FOR ADF SERIES

Entering Water Temperature 5 °C, differential temperature 5 °C (6 ROW COIL)

Model ADF-	Air Flow m ³ /hr	Entering Air DB (°C)	Entering Air WB (°C)											
			23			25			27			30		
			Capacity (1000Kcal/hr)		Water Flow Rate L/hr	Capacity (1000Kcal/hr)		Water Flow Rate L/hr	Capacity (1000Kcal/hr)		Water Flow Rate L/hr	Capacity (1000Kcal/hr)		Water Flow Rate L/hr
			Total	Sensible		Total	Sensible		Total	Sensible		Total	Sensible	
06	1020	35	9.68	6.38	1954	11.60	6.42	2342	13.65	6.42	2755	17.07	6.31	3445
		40	9.55	7.52	1928	11.47	7.58	2316	13.50	7.60	2724	16.87	7.60	3405
		45	9.44	8.61	1906	11.32	8.69	2284	13.37	8.74	2698	16.71	8.76	3373
08	1360	35	13.11	8.62	2646	15.62	8.63	3153	18.30	8.61	3695	22.79	8.43	4601
		40	12.95	10.15	2613	15.45	10.19	3119	18.11	10.19	3656	22.54	10.15	4550
		45	12.80	11.62	2584	15.25	11.69	3079	17.94	11.72	3622	22.33	11.71	4508
10	1700	35	14.65	9.82	2957	17.81	9.94	3595	21.16	9.98	4272	26.74	9.83	5397
		40	14.43	11.62	2913	17.59	11.79	3551	20.91	11.88	4221	26.41	11.90	5332
		45	14.98	13.99	3024	17.33	13.57	3497	20.69	13.71	4177	26.14	13.79	5277
12	2040	35	18.42	12.25	3718	22.18	12.33	4478	26.19	12.34	5287	32.88	12.11	6637
		40	15.17	14.46	3062	21.93	14.60	4427	25.90	11.65	5228	32.50	14.64	6561
		45	18.26	16.88	3687	21.62	16.79	4365	25.64	16.89	5176	32.18	16.93	6496
14	2380	35	22.15	14.65	4472	26.53	14.71	5356	31.21	14.70	6300	39.01	14.39	7875
		40	21.87	17.28	4414	26.24	17.39	5297	30.87	17.42	6231	38.57	17.37	7787
		45	21.61	19.82	4362	25.89	19.98	5226	30.58	20.06	6172	38.21	20.07	7713
16	2720	35	25.87	17.05	5222	30.87	17.08	6231	36.21	17.05	7310	45.14	16.67	9112
		40	25.55	20.09	5157	30.54	20.18	6165	35.83	20.19	7232	44.64	20.10	9012
		45	25.26	23.02	5100	30.14	23.16	6085	35.50	23.22	7166	44.23	23.20	8928
18	3060	35	29.58	19.44	5971	35.20	19.45	7106	41.21	19.39	8320	51.27	18.95	10349
		40	29.22	22.88	5899	34.84	22.96	7032	40.79	22.95	8233	50.71	22.83	10236
		45	28.91	26.21	5835	34.39	26.34	6943	40.42	26.39	8159	50.25	26.34	10143
20	3400	35	33.03	21.69	6668	39.25	21.68	7923	45.90	21.60	9265	-	-	-
		40	32.64	25.53	6589	38.85	25.58	7842	45.43	25.55	9170	-	-	-
		45	32.29	29.24	6519	38.36	29.35	7743	45.02	29.38	9089	-	-	-

COOLING CAPACITY RATINGS FOR ADF VERSION

Entering Water Temperature 7 °C , differential temperature 5 °C (6 ROW COIL)

Model ADF-	Air Flow m ³ /hr	Entering Air DB (°C)	Entering Air WB (°C)											
			23			25			27			30		
			Capacity (1000Kcal/hr)		Water Flow Rate L/hr	Capacity (1000Kcal/hr)		Water Flow Rate L/hr	Capacity (1000Kcal/hr)		Water Flow Rate L/hr	Capacity (1000Kcal/hr)		Water Flow Rate L/hr
			Total	Sensible		Total	Sensible		Total	Sensible		Total	Sensible	
06	1020	35	8.52	5.82	1720	10.44	5.88	2108	12.49	5.91	2521	15.90	5.85	3210
		40	8.40	6.93	1696	10.32	7.02	2084	12.35	7.07	2493	15.71	7.09	3172
		45	8.85	8.85	1786	10.18	8.12	2054	12.23	8.20	2469	15.56	8.24	3141
08	1360	35	11.59	7.88	2339	14.10	7.93	2847	16.78	7.94	3388	21.26	7.82	4291
		40	11.44	9.38	2310	13.95	9.47	2816	16.60	9.50	3352	21.02	9.49	4243
		45	11.83	11.29	2388	13.76	10.95	2778	16.45	11.01	3321	20.83	11.03	4204
10	1700	35	12.71	8.87	2565	15.89	9.06	3207	19.24	9.15	3884	24.80	9.11	5006
		40	12.49	10.60	2522	15.68	10.86	3164	19.00	11.00	3835	24.49	11.08	4944
		45	14.19	13.96	2864	15.42	12.60	3113	18.79	12.80	3794	24.23	12.94	4892
12	2040	35	15.12	11.13	3052	19.89	11.28	4016	23.90	11.34	4824	30.57	11.23	6170
		40	15.88	13.28	3206	19.65	13.50	3967	23.62	13.61	4768	30.21	13.65	6097
		45	17.31	16.83	3494	19.36	15.64	3909	23.38	15.81	4720	29.91	15.91	6037
14	2380	35	19.49	13.36	3934	23.88	13.49	4820	28.54	13.52	5761	36.32	13.35	7333
		40	19.22	15.93	3880	23.60	16.12	4765	28.23	16.21	5698	35.91	16.22	7249
		45	20.42	19.68	4121	23.27	18.66	4698	27.95	18.81	5643	35.56	18.88	7179
16	2720	35	22.84	15.58	4611	27.84	15.69	5621	33.18	15.70	6697	42.08	14.57	8494
		40	22.55	18.56	4551	27.54	18.73	5560	32.82	18.80	6626	41.61	18.78	8399
		45	23.52	22.54	4748	27.17	21.67	5484	32.52	21.80	6564	41.22	21.85	8320
18	3060	35	25.19	17.80	5085	31.81	17.89	6421	37.81	17.88	7632	47.83	17.59	9655
		40	25.86	21.18	5220	31.47	21.34	6353	37.41	21.40	7552	47.30	21.34	9548
		45	26.62	25.39	5373	31.06	24.68	6270	37.07	24.79	7484	46.87	24.82	9461
20	3400	35	28.29	19.88	5710	35.50	19.95	7165	42.13	19.92	8505	53.22	19.57	10743
		40	28.93	23.65	5839	35.13	23.80	7091	41.70	23.84	8417	52.64	23.75	10626
		45	29.60	28.19	5976	34.67	27.52	6999	41.33	27.62	8343	52.16	27.62	10530

COOLING CAPACITY RATINGS FOR ADF VERSION

Entering Water Temperature 10 C, differential temperature 5 C (6 ROW COIL)

Model ADF-	Air Flow m ³ /hr	Entering Air DB (°C)	Entering Air WB (°C)											
			23			25			27			30		
			Capacity (1000Kcal/hr)		Water Flow Rate L/hr	Capacity (1000Kcal/hr)		Water Flow Rate L/hr	Capacity (1000Kcal/hr)		Water Flow Rate L/hr	Capacity (1000Kcal/hr)		Water Flow Rate L/hr
			Total	Sensible		Total	Sensible		Total	Sensible		Total	Sensible	
06	1020	35	6.60	4.90	1333	8.55	5.04	1726	10.60	5.11	2140	14.00	5.15	2827
		40	6.92	6.30	1397	8.44	6.14	1705	10.48	6.24	2115	13.84	6.32	2793
		45	8.12	8.12	1638	8.31	7.19	1678	10.37	7.33	2093	13.70	7.44	2765
08	1360	35	9.10	6.70	1837	11.63	6.84	2348	14.31	6.90	2889	18.77	6.90	3789
		40	9.28	8.38	1873	11.50	8.32	2321	14.15	8.42	2857	18.55	8.47	3745
		45	10.85	10.85	2190	11.33	9.75	2288	14.02	9.88	2830	18.38	9.98	3710
10	1700	35	9.45	7.24	1908	12.72	7.64	2568	16.10	7.84	3250	21.65	7.95	4371
		40	11.01	10.29	2222	12.55	9.35	2533	15.88	9.61	3206	21.37	9.81	4313
		45	13.00	13.00	2624	13.03	11.57	2631	15.72	11.35	3172	21.16	11.62	4271
12	2040	35	12.32	9.28	2487	16.15	9.61	3259	20.16	9.78	4070	26.81	9.85	5413
		40	13.49	12.44	2724	15.93	11.73	3216	19.92	11.97	4020	26.48	12.13	5346
		45	15.86	15.86	3202	15.90	13.96	3210	19.72	14.10	3981	26.21	14.33	5291
14	2380	35	15.11	11.26	3051	19.54	11.56	3944	24.21	11.70	4887	31.96	11.74	6452
		40	15.97	14.59	3223	19.30	14.09	3896	23.92	14.31	4829	31.58	14.44	6375
		45	18.72	18.72	3779	19.00	16.52	3835	23.69	16.83	4782	31.27	17.04	6313
16	2720	35	17.88	13.22	3609	22.91	13.50	4625	28.24	13.63	5702	37.11	13.64	7491
		40	18.43	16.72	3721	22.65	16.44	4572	27.93	16.64	5638	36.68	16.75	7404
		45	21.57	21.57	4354	22.31	19.27	4504	27.66	19.56	5584	36.33	19.76	7335
18	3060	35	20.63	15.17	4165	26.28	15.44	5305	32.28	15.55	6515	42.26	15.54	8530
		40	20.90	18.85	4218	25.99	18.78	5246	31.93	18.97	6445	41.78	19.06	8433
		45	24.42	24.42	4929	25.62	22.00	5172	31.63	22.29	6386	41.39	22.47	8355
20	3400	35	23.15	16.98	4674	29.39	17.25	5932	36.02	17.34	7270	47.05	17.30	9498
		40	23.26	20.94	4695	29.07	20.98	5868	35.63	21.16	7193	46.53	21.22	9393
		45	27.16	27.16	5483	28.68	24.57	5789	35.31	24.85	7129	46.11	25.02	9307

HEATING CAPACITY RATINGS FOR ADF VERSION

Entering Water Temperature 75 °C, differential temperature 10 °C (4ROW COIL)

Model ADF-	Air Flow m ³ /hr	Entering Air DB (°C)									
		10		15		20		25		30	
		Capacity (1000Kcal/hr)	Water Flow Rate (L/hr)	Capacity (1000Kcal/hr)	Water Flow Rate (L/hr)	Capacity (1000Kcal/hr)	Water Flow Rate (L/hr)	Capacity (1000Kcal/hr)	Water Flow Rate (L/hr)	Capacity (1000Kcal/hr)	Water Flow Rate (L/hr)
06	1020	14.15	1428	12.76	1288	11.48	1158	10.21	1031	8.97	905
08	1360	18.74	1892	16.93	1708	15.23	1537	13.57	1370	11.94	1205
10	1700	23.34	2356	21.10	2129	19.00	1917	16.94	1709	14.91	1505
12	2040	28.22	2849	25.52	2575	22.99	2320	20.51	2070	18.07	1824
14	2380	33.11	3342	29.94	3022	26.98	2724	24.08	2431	21.23	2143
16	2720	36.82	3716	33.22	3353	29.87	3014	26.57	2681	23.32	2354
18	3060	41.69	4208	37.63	3798	33.85	3416	30.13	3041	26.47	2672
20	3400	46.28	4671	41.79	4218	37.60	3795	33.48	3380	29.44	2971

Entering Water Temperature 80 °C, differential temperature 10 °C (4ROW COIL)

Model ADF-	Air Flow m ³ /hr	Entering Air DB (°C)									
		10		15		20		25		30	
		Capacity (1000Kcal/hr)	Water Flow Rate (L/hr)	Capacity (1000Kcal/hr)	Water Flow Rate (L/hr)	Capacity (1000Kcal/hr)	Water Flow Rate (L/hr)	Capacity (1000Kcal/hr)	Water Flow Rate (L/hr)	Capacity (1000Kcal/hr)	Water Flow Rate (L/hr)
06	1020	15.35	1549	14.03	1416	12.74	1286	11.50	1160	10.27	1036
08	1360	20.38	2057	18.58	1875	16.91	1706	15.26	1541	13.65	1378
10	1700	25.93	2617	23.64	2386	21.53	2173	16.45	1660	17.40	1756
12	2040	31.36	3165	28.61	2887	26.05	2630	23.55	2377	21.09	2129
14	2380	36.79	3713	33.57	3388	30.59	3087	27.66	2792	24.78	2501
16	2720	42.23	4262	38.54	3890	35.12	3545	31.77	3206	28.47	2874
18	3060	47.67	4811	43.51	4392	39.66	4003	35.88	3621	32.17	3247
20	3400	52.82	5332	48.23	4868	43.97	4438	39.78	4015	35.67	3601

HEATING CAPACITY RATINGS FOR ADF VERSION

Entering Water Temperature 85 °C, differential temperature 10 °C (4ROW COIL)

Model ADF-	Air Flow m ³ /hr	Entering Air DB (°C)									
		10		15		20		25		30	
		Capacity (1000Kcal/hr)	Water Flow Rate (L/hr)	Capacity (1000Kcal/hr)	Water Flow Rate (L/hr)	Capacity (1000Kcal/hr)	Water Flow Rate (L/hr)	Capacity (1000Kcal/hr)	Water Flow Rate (L/hr)	Capacity (1000Kcal/hr)	Water Flow Rate (L/hr)
06	1020	16.58	1674	15.17	1531	13.86	1399	12.57	1269	11.31	1142
08	1360	21.91	2212	20.13	2031	18.38	1855	16.67	1682	15.01	1515
10	1700	27.30	2755	24.99	2523	22.86	2307	20.77	2096	18.71	1888
12	2040	32.97	3328	30.20	3048	27.63	2788	25.11	2534	22.63	2284
14	2380	38.65	3901	35.40	3573	32.40	3270	29.45	2972	26.55	2680
16	2720	43.21	4361	39.52	3989	36.10	3644	32.75	3306	29.46	2973
18	3060	48.86	4932	44.70	4512	40.86	4124	37.08	3742	33.37	3368
20	3400	54.21	5472	49.61	5007	45.35	4577	41.17	4155	37.06	3740

Performance Data

AIR DELIVERY m³/hr - 50 Hz MOTOR

UNIT SIZE	ADFA								
	FAN SPEED								
	ROW	LOW	MED	HIGH					
	EXTERNAL STATIC PRESSURE (mm H2O)								
	0			2.5	5	6.3	7.6	10	
06	4	800	1160	1490	1410	1290	1240	1190	1050
	6	800	1150	1290	1200	1120	1050	1000	-
08	4	1580	1870	2040	1920	1800	1750	1650	1440
	6	1560	1680	1770	1630	1530	1440	1390	1220
10	4	1590	1950	2260	2170	2020	1970	1890	1740
	6	1580	1850	2020	1900	1800	1730	1660	1480
12	4	1600	2320	2980	2820	2580	2480	2380	2100
	6	1600	2300	2580	2400	2240	2100	2000	-
14	4	3180	3520	3710	3480	3210	3130	3000	2690
	6	2850	2990	3100	2890	2720	2600	2410	2190
16	4	3150	3740	4080	3840	3600	3500	3300	2960
	6	3120	3360	3540	3260	3060	2880	2780	2440
18	4	3140	3820	4320	4100	3830	3670	3580	3220
	6	3120	3570	3740	3570	3220	3180	3030	2730
20	4	3180	3900	4520	4340	4040	3940	3740	3480
	6	3160	3700	4040	3800	3600	3460	3320	2960

AIR DELIVERY m³/hr - 50 Hz MOTOR

UNIT SIZE	ADFC , FE , FF								
	FAN SPEED								
	ROW	LOW	MED	HIGH					
	EXTERNAL STATIC PRESSURE (mm H2O)								
	0			2.5	5	6.3	7.6	10	
06	4	820	1190	1430	1360	1290	1200	1120	970
	6	730	1100	1250	1160	1080	990	920	-
08	4	1530	1730	1990	1840	1730	1650	1530	1410
	6	1460	1610	1690	1580	1420	1380	1330	1200
10	4	1580	1780	2200	2070	1900	1830	1760	3630
	6	1560	1740	1960	1870	1740	1660	1580	1430
12	4	1600	2400	2800	2620	2430	2330	2200	1950
	6	1600	2180	2400	2300	2060	1910	1800	-
14	4	3090	3220	3500	3280	3030	2910	2780	2430
	6	2760	2890	2980	2770	2530	2420	2290	-
16	4	3160	3600	3830	3590	3400	3210	3050	2800
	6	2920	3180	3220	3080	2840	2770	2640	2280
18	4	3160	3790	4120	3880	3690	3550	3330	3020
	6	3090	3500	3610	3400	3140	3070	2940	2550
20	4	3160	3860	4330	4080	3850	3680	3550	3200
	6	3120	3620	3830	3600	3390	3250	3110	2810

Performance Data

ADF SERIES COOLING CAPACITY CORRECTION FACTORS

Actual Air Flow m ³ /hr	UNIT SIZE															
	06		08		10		12		14		16		18		20	
	TH	SH	TH	SH	TH	SH	TH	SH	TH	SH	TH	SH	TH	SH	TH	SH
170	-	-	-	-	-	-	-	-	-	-	-	-	-	-	-	-
213	-	-	-	-	-	-	-	-	-	-	-	-	-	-	-	-
255	-	-	-	-	-	-	-	-	-	-	-	-	-	-	-	-
297.5	-	-	-	-	-	-	-	-	-	-	-	-	-	-	-	-
340	0.46	0.41	-	-	-	-	-	-	-	-	-	-	-	-	-	-
383	0.51	0.45	-	-	-	-	-	-	-	-	-	-	-	-	-	-
425	0.55	0.49	-	-	-	-	-	-	-	-	-	-	-	-	-	-
468	0.58	0.53	0.47	0.42	-	-	-	-	-	-	-	-	-	-	-	-
510	0.62	0.57	0.51	0.45	0.43	0.38	-	-	-	-	-	-	-	-	-	-
595	0.69	0.65	0.57	0.50	0.48	0.46	-	-	-	-	-	-	-	-	-	-
680	0.76	0.73	0.62	0.57	0.53	0.47	0.46	0.41	-	-	-	-	-	-	-	-
765	0.82	0.80	0.67	0.63	0.58	0.52	0.51	0.45	-	-	-	-	-	-	-	-
850	0.89	0.87	0.72	0.69	0.62	0.57	0.55	0.47	-	-	-	-	-	-	-	-
935	0.95	0.94	0.77	0.74	0.66	0.62	0.58	0.53	0.57	0.47	-	-	-	-	-	-
1020	1.00	1.00	0.82	0.80	0.70	0.67	0.62	0.57	0.58	0.53	-	-	-	-	-	-
1190	1.11	1.12	0.92	0.91	0.78	0.76	0.69	0.65	0.62	0.57	0.57	0.50	-	-	-	-
1360	1.18	1.22	1.00	1.00	0.86	0.85	0.76	0.73	0.68	0.64	0.62	0.57	0.57	0.51	-	-
1530	-	-	1.08	1.08	0.94	0.93	0.82	0.80	0.74	0.80	0.67	0.63	0.62	0.57	0.58	0.52
1700	-	-	1.16	1.18	1.00	1.00	0.89	0.87	0.82	0.80	0.72	0.69	0.68	0.65	0.62	0.57
2040	-	-	-	-	1.13	1.14	1.00	1.00	0.90	0.89	0.82	0.80	0.76	0.72	0.70	0.67
2380	-	-	-	-	-	-	1.11	1.12	1.00	1.00	0.92	0.91	0.84	0.82	0.78	0.76
2720	-	-	-	-	-	-	1.18	1.22	1.10	1.11	1.00	1.00	0.93	0.92	0.86	0.85
3060	-	-	-	-	-	-	-	-	-	-	1.08	1.08	1.00	1.00	0.94	0.93
3400	-	-	-	-	-	-	-	-	-	-	1.16	1.18	1.07	1.07	1.00	1.00
3740	-	-	-	-	-	-	-	-	-	-	-	-	-	-	1.07	1.07
4080	-	-	-	-	-	-	-	-	-	-	-	-	-	-	1.13	1.14

SH - Sensible Heat

TH - Total Heat

NOTE : Use Sensible Heat correction factors when calculating heating capacity .

ALTITUDE COOLING CORRECTION

Elevation (m)	Total Heat	Sensible Heat
305	0.99	0.96
610	0.98	0.93
915	0.97	0.89
1220	0.96	0.86
1524	0.94	0.83
1829	0.93	0.80

Performance Data

WATER PRESSURE DROP (mH2O)

ADF MODEL	ROW	Water Flow (L/hr)													
		100	300	500	700	900	1100	1300	1500	1700	1900	2100	2400	2700	3000
06	4	0.012	0.14	0.28	0.48	0.65	1.00	1.30	1.40	1.80	2.10	2.3	3.00	3.50	4.10
	6	0.012	0.13	0.25	0.38	0.60	0.90	1.25	1.50	1.80	2.00	2.5	2.90	3.50	4.00
08	4	0.015	0.17	0.33	0.58	0.80	1.30	1.55	1.80	2.30	2.80	3.1	3.90	4.50	5.40
	6	0.014	0.15	0.30	0.45	0.70	1.10	1.40	1.75	2.00	2.20	2.8	3.20	4.00	4.50
10	4	0.011	0.13	0.25	0.45	0.60	0.90	1.20	1.30	1.70	2.00	2.25	2.90	3.40	4.00
	6	0.014	0.15	0.30	0.45	0.70	1.10	1.40	1.75	2.00	2.20	2.8	3.20	4.00	4.50
12	4	0.012	0.14	0.28	0.48	0.65	1.00	1.30	1.40	1.80	2.10	2.3	3.00	3.50	4.10
	6	0.016	0.17	0.35	0.55	0.80	1.30	1.60	2.00	2.40	2.80	3.2	3.90	4.50	5.20
14	4	0.012	0.14	0.28	0.48	0.65	1.00	1.30	1.40	1.80	2.10	2.3	3.00	3.50	4.10
	6	0.010	0.05	0.10	0.16	0.25	0.35	0.48	0.52	0.65	0.80	0.9	1.20	1.40	1.70
16	4	0.010	0.35	0.07	0.12	0.17	0.28	0.32	0.38	0.48	0.55	0.600	0.80	0.95	1.20
	6	0.010	0.06	0.12	0.18	0.28	0.40	0.51	0.60	0.75	0.90	1.000	1.40	1.60	1.90
18	4	0.010	0.05	0.11	0.18	0.23	0.40	0.50	0.58	0.75	0.90	1.000	1.30	1.50	1.70
	6	0.010	0.06	0.14	0.20	0.30	0.45	0.60	0.70	0.85	1.00	1.200	1.50	1.70	2.00
20	4	0.010	0.08	0.17	0.23	0.40	0.60	0.75	0.90	1.20	1.40	1.700	1.80	2.20	2.80
	6	0.010	0.07	0.15	0.22	0.03	0.50	0.70	0.80	0.95	1.20	1.400	1.70	1.80	2.20

WATER PRESSURE DROP (mH2O)

ADF MODEL	ROW	Water Flow (L/hr)													
		3300	3600	3900	4200	4500	4800	5300	6000	6500	7000	7500	8000	9000	10500
06	4	4.50	5.50	6.00	7.00	7.50	8.50	10.00	—	—	—	—	—	—	—
	6	4.50	5.00	6.00	6.50	7.50	8.00	9.80	—	—	—	—	—	—	—
08	4	6.00	7.00	7.50	8.80	9.50	10.00	—	—	—	—	—	—	—	—
	6	5.20	6.00	7.00	7.50	8.50	9.00	—	—	—	—	—	—	—	—
10	4	4.40	5.40	5.90	6.90	7.40	8.40	9.00	—	—	—	—	—	—	—
	6	5.20	6.00	7.00	7.50	8.50	9.00	—	—	—	—	—	—	—	—
12	4	4.50	5.50	6.00	7.00	7.50	8.50	10.00	—	—	—	—	—	—	—
	6	6.00	7.00	8.00	9.00	10.00	10.00	—	—	—	—	—	—	—	—
14	4	4.50	5.50	6.00	7.00	7.50	8.50	10.00	—	—	—	—	—	—	—
	6	1.90	2.10	2.50	2.80	3.00	3.20	4.00	4.50	5.00	5.20	5.50	6.50	8.00	10.00
16	4	1.30	1.50	1.70	1.80	2.00	2.20	2.80	3.20	3.50	3.80	4.20	4.80	5.50	7.00
	6	2.10	2.30	2.80	3.00	3.30	3.50	4.30	5.00	6.00	6.20	6.50	7.80	9.00	—
18	4	1.90	2.20	2.70	3.00	3.20	3.50	4.00	4.80	5.20	5.80	6.50	7.00	8.00	—
	6	2.30	2.70	3.00	3.30	3.80	4.00	5.00	5.80	6.80	7.50	7.80	9.00	10.00	—
20	4	3.00	3.30	4.00	4.20	4.80	5.00	6.20	7.20	8.00	9.00	9.50	—	—	—
	6	2.70	3.00	3.20	3.90	4.10	4.50	5.50	6.50	8.00	8.50	8.80	—	—	—

DIMENSION

All dimensions are given in mm

MODEL: ADFA
FURRED-IN CEILING (without plenum)

MODEL	A	B	C
ADFA-06	612	382	455
ADFA-08	714	484	557
ADFA-10	816	586	659
ADFA-12	943	713	786
ADFA-14	1070	840	913
ADFA-16	1197	967	1040
ADFA-18	1324	1094	1167
ADFA-20	1426	1196	1269

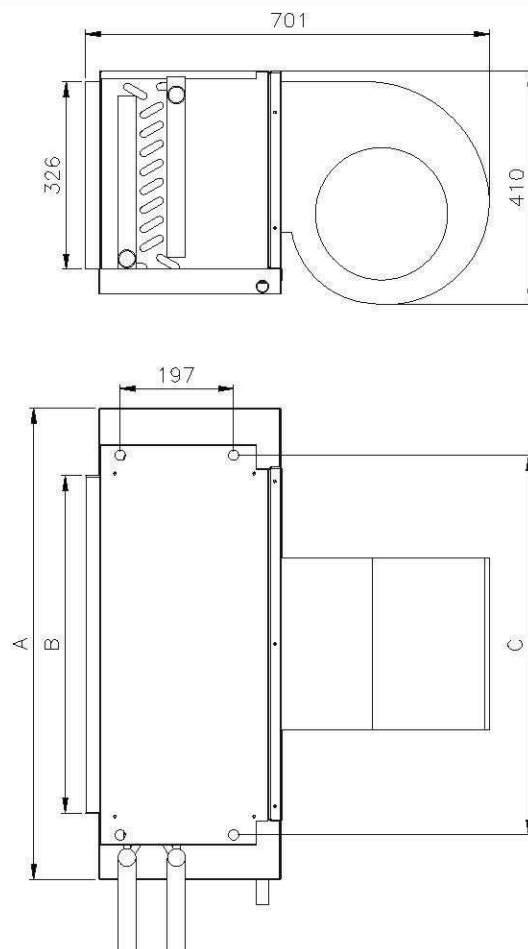

DIMENSION

All dimensions are given in mm

MODEL: ADFC FURRED-IN CEILING WITH PLENUM

MODEL	A	B	C	D	E
ADFC-06	612	666	382	455	535
ADFC-08	714	768	484	557	637
ADFC-10	816	870	586	659	739
ADFC-12	943	997	713	786	866
ADFC-14	1070	1124	840	913	993
ADFC-16	1197	1251	967	1040	1120
ADFC-18	1324	1378	1094	1167	1247
ADFC-20	1426	1480	1196	1269	1349

INLET BACK

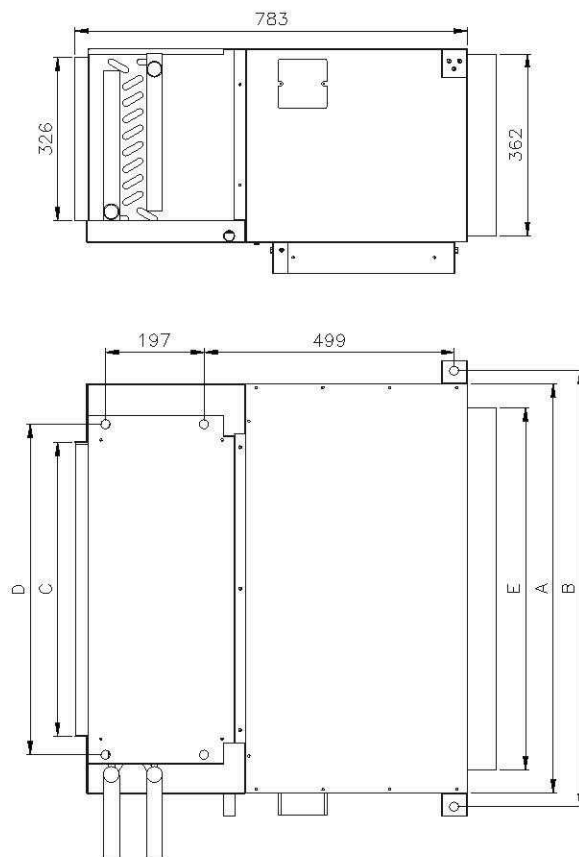

INLET DOWN

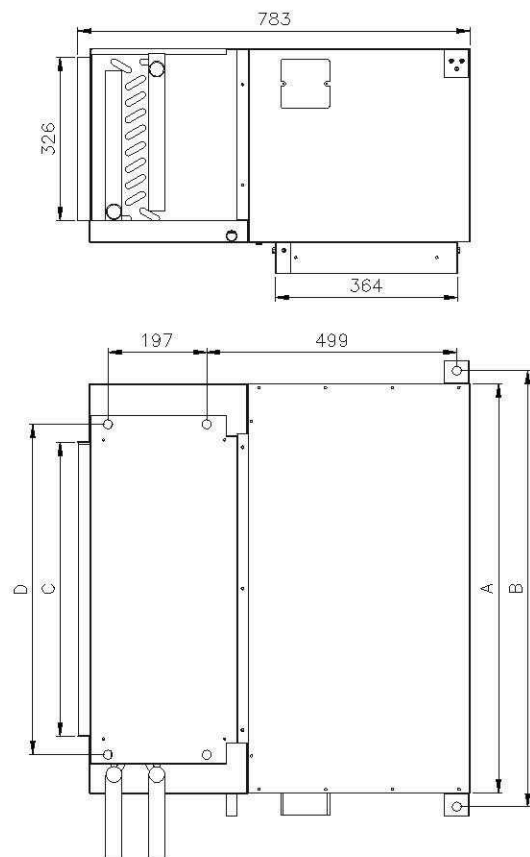

DIMENSION

All dimensions are given in mm

MODEL: ADFE CEILING WITH FULL CASING

MODEL	A	B	C	D
ADFE-06	710	418	344	372
ADFE-08	812	520	446	474
ADFE-10	914	622	548	576
ADFE-12	1041	749	675	703
ADFE-14	1168	876	802	830
ADFE-16	1295	1003	929	957
ADFE-18	1422	1130	1056	1084
ADFE-20	1524	1232	1158	1186

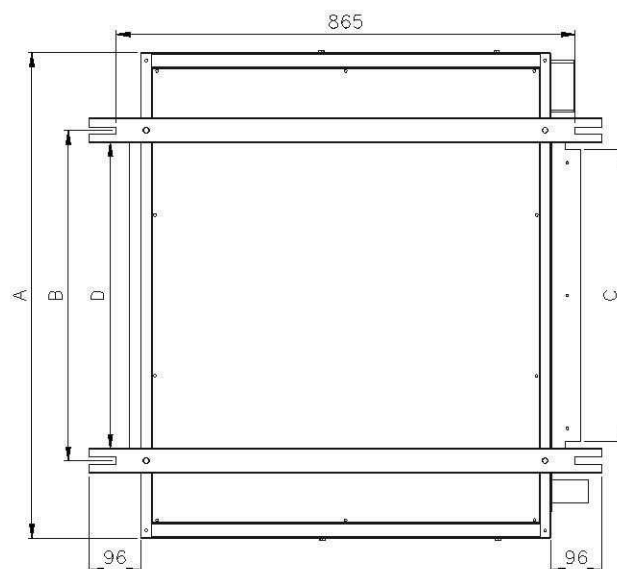
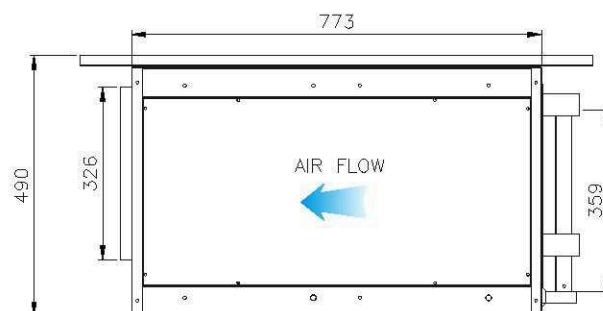

DIMENSION

All dimensions are given in mm

MODEL: ADFF EXPOSED CEILING CABINET

MODEL	A	B	C	D
ADFF-06	710	418	344	372
ADFF-08	812	520	446	474
ADFF-10	914	622	548	576
ADFF-12	1041	749	675	703
ADFF-14	1168	876	802	830
ADFF-16	1295	1003	929	957
ADFF-18	1422	1130	1056	1084
ADFF-20	1524	1232	1158	1186

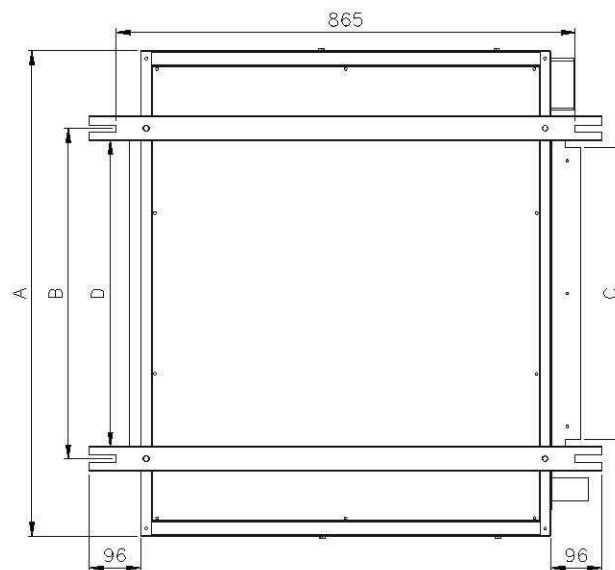
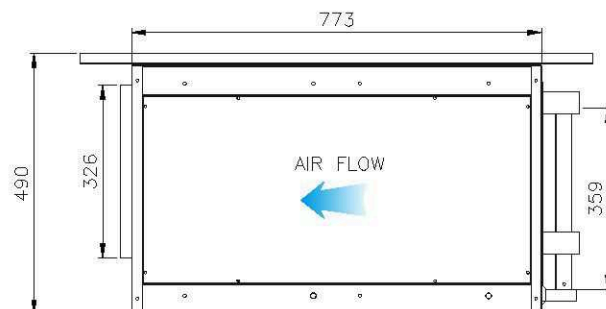

Guide specifications

Ducted Fan Coil Unit

HVAC Guide specifications

Equipment location flexibility.

Efficient operation

Size Range : 1020 to 3400 Nominal m³/hr

Model Number :

Part 1 - General

1.01 - SYSTEM DESCRIPTION

Horizontal, 2-pipe or electric heat fan coil unit for ducted installations; horizontal furred-in or exposed ceiling model, ceiling cabinet, or vertical model with galvanized casing for closet or utility room installation.

Part 2 - Products

2.01 - EQUIPMENT

A. General :

Factory assembled, horizontal blow-thru ducted fan coil unit shall be complete with water coil(s), fan(s), motor(s), drain pan, and all required wiring, piping and special features.

B. Horizontal, Furred-in Base Unit (ADFA) :

1- Outside panels shall be galvanized steel, lined on the inside with 20mm thick plastophom insulation and a one-in. Long collar for supply duct connection.

2- The drain pan shall be constructed of galvanized steel extending the entire length and width of the coil(s) and pitched for drainage.

C. Horizontal Base Unit with Plenum for Concealed installation (ADFC) :

Unit shall have a factory-installed, galvanized steel plenum section and one-in. Throwaway filter. The plenum shall be either bottom or

rear return, lined with 20mm plastophom insulation and include a removable panel to provide access to the fan/motor assembly.

D. Horizontal, Enclosed Unit for Concealed Installation (ADFE) :

Unit shall be constructed of galvanized steel with removable panels for access to internal components. Units have 20mm plastophom insulation, filter track with one-in. Throwaway filter.

E. Horizontal Cabinet Unit for Exposed Installation (ADFF) .

Unit shall be constructed of steel with champagne beige re-coatable baked enamel finish. Cabinet shall be lined with 20mm plastophom insulation and have removable bottom access panel.

Unit shall include hinged bar type return air grille on rear of unit with one-in. Throwaway filter and integral double deflection supply grille.

F. Fans :

Direct-driven, double-width fan wheels shall have forward-curved blades, and be statically and dynamically balanced with scrolls and fans constructed of galvanized steel.

G. Coils :

Standard base unit shall be equipped with a 4-row coil for installation in a 2-pipe system; Copper tubes with very high efficiency louvred v-waffle type.

Aluminum fins bonded to the tubes by mechanical expansion and have a working pressure of 250 psig.



 ASGHARIAN
HOLDING



استان مازندران - آمل
خیابان امام خمینی (ره) - نبش آفتاب ۲۷ - پلاک ۶۱
دپارتمان مارکتینگ: ۰۹۱۱۴۶۰۶۱۶۹
مدیریت فروش: ۰۹۱۱۳۱۰۳۸۲۸
www.asgharianco.com
sales@asgharianco.com
marketing@asgharianco.com