



استان مازندران - آمل
 خیابان امام خمینی (ره) - نبش آفتاب ۲۷ - پلاک ۶۱
 دپارتمان مارکتینگ: ۰۹۱۱۴۶۰۶۱۶۹
 مدیریت فروش: ۰۹۱۱۳۱۰۳۸۲۸
www.asgharianco.com
sales@asgharianco.com
marketing@asgharianco.com



All products specified in this brochure comply with the Australian Communications Authority's (ACA) requirements for Electromagnetic Compatibility (EMC).

ISO 9001 Certified number: 100 78286 Fujitsu General (Shanghai) Co., Ltd.
 ISO 14001 Certified number: 104682
 ISO 9001 Certified number: 100 89294 Fujitsu General (Thailand) Co., Ltd.
 ISO 14001 Certified number: 104 9245

AIRSTAGE™ is a worldwide trademark of FUJITSU GENERAL LIMITED.

*Microsoft® and Windows® are registered trademarks of Microsoft Corporation in the United States.

*Adobe® and Acrobat Reader® are registered trademarks of Adobe Systems Incorporated in the United States.

*Intel®, Pentium® and Celeron® are registered trademarks of Intel Corporation or its subsidiaries in the United States.

*AMD Athlon™ and AMD Duron™ are registered trademarks of Advanced Micro Devices, Inc.

*Echelon®, LON®, LONWORKS®, LonTalk®, Neuron®, 3120®, 3150®, LNS®, iLON®, LonMaker®, and the Echelon logo are trademarks of Echelon Corporation registered in the United States and other countries.

*BACnet® is a registered trademark of the American Society of Heating Refrigeration and Air Conditioning Engineers (ASHRAE).

*An XLON® USB adaptor is provided. (XLON® is a registered trademark of DH electronics company GmbH.)

All specifications subject to change without prior notice.

Copyright © 2002-2005 Fujitsu General Limited. All rights reserved.

Distributed by :

FUJITSU GENERAL LIMITED
 1116, Suenaga, Takatsu-ku, Kawasaki 213-8502, Japan
 URL : <http://www.fujitsu-general.com>

VB008E/05 Printed in Japan



R22 & R407C

AIRSTAGE™

Variable Refrigerant Flow System
 Multi Air Conditioning System for Buildings

The Intelligent Choice in Comfort

S SERIES



FUJITSU GENERAL LIMITED

Building air conditioning de

Providing highly efficient, energy-saving operation.

HEAT PUMP & COOLING ONLY SERIES



A high-performance operating system utilising innovative triple high-efficiency compressors and advanced refrigerant flow control technology (Power Balance Technology). The result is superior energy savings and impressively low operating noise. Capable of connecting up to 13 (22.4kW) or 16 (28kW) indoor units to one outdoor unit.



OUTDOOR UNITS LINE UP

R407C			R22		
	Heat Pump Type AO90TPCMF(28kW)	Cooling Only Type AO90EPCMF(28kW)		Heat Pump Type AO90RPCMF(28kW)	Cooling Only Type AO90APCMF(28kW)
	AO72TPCMF(22.4kW)	AO72EPCMF(22.4kW)		AO72RPCMF(22.4kW)	AO72APCMF(22.4kW)

INDOOR UNIT

INDOOR UNITS LINE UP

Choose the right indoor unit to match the building requirements. Various combinations of indoor unit type and capacity 12 types 45 models, ranging from 2.15kW to 17.0kW.

<p>Cassette Type (Compact)</p> <p>Compact design for easy installation and maintenance.</p> <p>see page 26</p>	<p>Cassette Type</p> <p>Slim cassette designed for restricted ceiling voids.</p> <p>Compact but powerful for all user applications.</p> <p>see page 27</p>	<p>Duct Type (Compact)</p> <p>Equally suitable for ceiling installation or at floor level.</p> <p>see page 28</p>	<p>Duct Type</p> <p>Ultra-slim duct air conditioner for those tight ceiling spaces.</p> <p>see page 28</p>	<p>High Static Pressure Duct Type</p> <p>High static pressure duct type with no installation restrictions.</p> <p>see page 29</p>
---	---	--	---	--

RB (Refrigerant Branch) Unit



Multi Type
Model : UTF-Y90A4A



Single Type
Model : UTF-Y54A1A

Separation tube

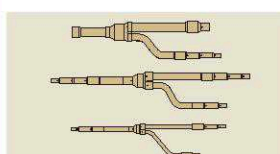

For Heat recovery
Model : UTR-BP90MA
UTR-BP54MA
Separation tubes are available for installation as necessary.

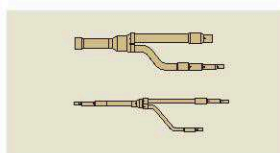

For Heat pump / Cooling only
Model : UTR-BP90TA
UTR-BP54TA
Separation tubes are available for installation as necessary.

Header

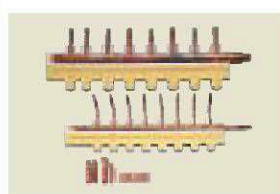

For Heat pump / Cooling only
Model : UTR-HD908A
For Heat recovery
Model : UTR-HD908R
Headers are available for installation as necessary.
*Reducer is attached to each header kit.

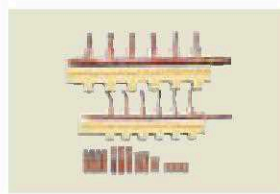

Heat pump / Cooling only
Model : UTR-HD906A
For Heat recovery
Model : UTR-HD906R
Headers are available for installation as necessary.
*Reducer is attached to each header kit.

Grille kit

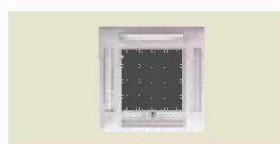

Model : UTG-UDYD-W
UTG-UDGD-W
Grille for compact cassette type indoor unit.

Flange

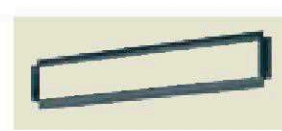

[Square]
Model : UTD-SF045T
For low pressure duct type
205 x 1,063, L=40 (mm)



[Round]
Model : UTD-RF204
For low pressure duct type
φ195 (φ205), L=85 (mm)

Outlet chamber



Model : UTD-BC200
φ195 (φ200), L=85,
Base size: H x W x D (mm)
297 x 1,066 x 400

Flexible duct

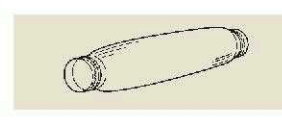

Model : UTD-RD202
For high static pressure duct type
φ200, L=2m

Drain water riser kit

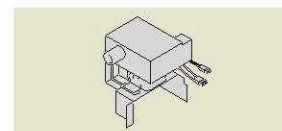

Model : UTR-DPB241
For ceiling type

Long-life filter

Model : UTD-LF270
For low static pressure duct type
Model : UTD-LF400
For high static pressure duct type

Remote sensor unit



Model : UTD-RS100
Thermo-sensor for sensing the temperature of arbitrary place in the room

Optional Parts

As for the other optional parts, refer to the other page of this catalog.

Network Converter Model : UTR-YRDA



•This network converter is to be used for connecting single split system or group remote controller with the VRF system.

•Please select the function by switching the dip switch during the installation work.

Dimensions (mm)
(H x W x D) : 67 x 288 x 211
Weight (g) : 1,500

- Split type systems can be controlled from a central remote controller or PC controller by connecting it to the VRF's network converter.
- Standard remote controller and central remote controller provide On/Off control, master control, temperature and fan control, etc.
- Up to 16 single units can be connected to and controlled with Network converter.
- Up to 100 units of Network converter can be connected in a single VRF transmission system.

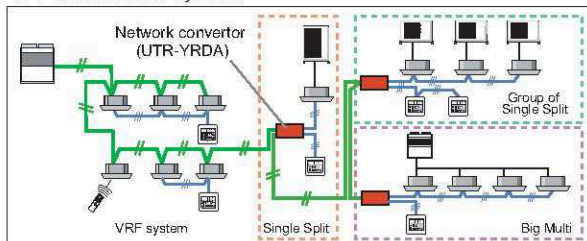

- For connection between Group remote controller and VRF system.



BACnet® Gateway [Software] Model : UTR-YLBA

- The central control of maximum 1600 indoor units can be realized by connecting the VRF system to the BACnet®, a global standard of the open network
- ANSI / ASHRAE Standards 135-2001 BACnet Application Specific Controller (B-ASC) BACnet® / IP over Ethernet
- It can be connected up to 4 systems (1600 indoor units / 400 outdoor units) for 1 gateway.
- It can be corresponded to the large-scale buildings and hotels etc.

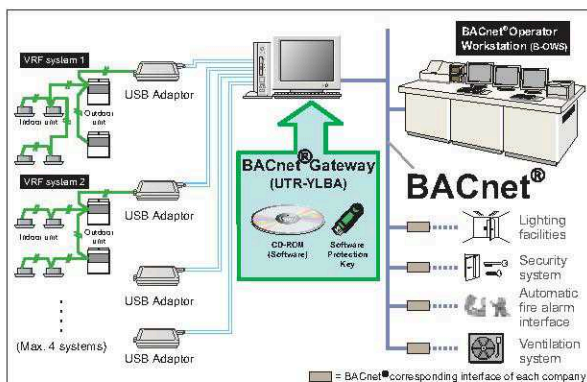

*USB Adaptor is XLON® USB Adaptor of DH electronics company.
**Twisted pair cable [22AWG(0.65mm) Level 4 shielded cable recommendation]

Network Converter Model : UTR-YLLA



Dimensions (mm)
(H x W x D) : 67 x 288 x 211
Weight (g) : 1,500

- For connection between VRF system and a LONWORKS® open network for the management of a small to medium-sized BMS and VRF system.
- By using the UTR-YLLA, the VRF system can be centrally controlled or monitored from a BMS with a LONWORKS® interface.
- Up to 128 Indoor units can be connected to 1 unit of Network Converter.

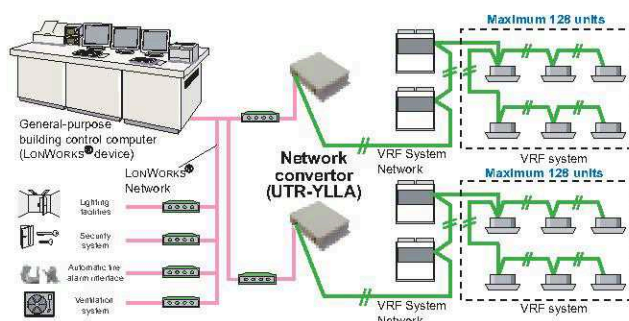

Transmission Adaptor Model : UTR-YTMA



Dimensions (mm)
(H x W x D) : 100 x 288 x 110
Weight (g) : 1,300

- For the air condition of the medium and large size building, the control software can control and monitor the air conditioners together with the ones in the other buildings.
- This device enables control by other equipment via an Inter Link cable.

Signal Amplifier Model : UTR-YRPC



Dimensions (mm)
(H x W x D) : 67 x 288 x 211
Weight (g) : 1,500

- This unit allows the connection of the following number of units:
(1) Transmission Line : Max. 2000m
(2) Connectable Units : Max. Indoor Unit : 400 units
Max. Outdoor Unit : 100 units
Max. Central Remote Controller : 16 unit
- Up to 8 signal amplifiers can be installed in a single VRF system.
- A signal amplifier is required,
(1) When the total wiring length of the transmission line exceeds 500m.
(2) When the total number of devices on the transmission line exceeds 62.

veloped to care for people

Non-inverter system free of electrical noise emissions.

HEAT RECOVERY SERIES

A high-performance operating system utilising innovative triple high-efficiency compressors and advanced refrigerant flow control technology (Power Accumulation Technology). With heat recovery operation, cooling and heating can be performed simultaneously and automatically within the same refrigerant system. This approach provides maximum energy efficiencies. Capable of connecting up to 16 (28kW) indoor units to one outdoor unit.

OUTDOOR UNIT

R407C

Heat Recovery Type
AO90MPBMF(28kW)

Floor & Ceiling Universal Type



This slim unit can be ceiling mounted or installed floor standing. Features double auto swing louvers.

see page 29

Ceiling Type



Attractive design and ultra-slim build still permits extra wide air flow. Features double auto swing louvers and extremely quiet.

see page 30

Wall Mounted Type (Compact)



Vertical and horizontal symmetrical design matched to the interior decor.

- Wall Mounted Type (Compact) indoor unit can't be operated in the Heat Recovery Type System.

see page 30

Wall Mounted Type



"Double Auto Swing" feature provides Omni-Directional Air Flow control

see page 31

Ceiling Wall Type



Discreet air intake is part of its attractive design. Double auto swing louvers.

see page 31

New operating system achieves high stan



Heat Pump Type
AO90TPCMF(28kW)
AO72TPCMF(22.4kW)

Cooling Only Type
AO90EPCMF(28kW)
AO72EPCMF(22.4kW)



Heat Pump Type
AO90RPCMF(28kW)
AO72RPCMF(22.4kW)

Cooling Only Type
AO90APCMF(28kW)
AO72APCMF(22.4kW)

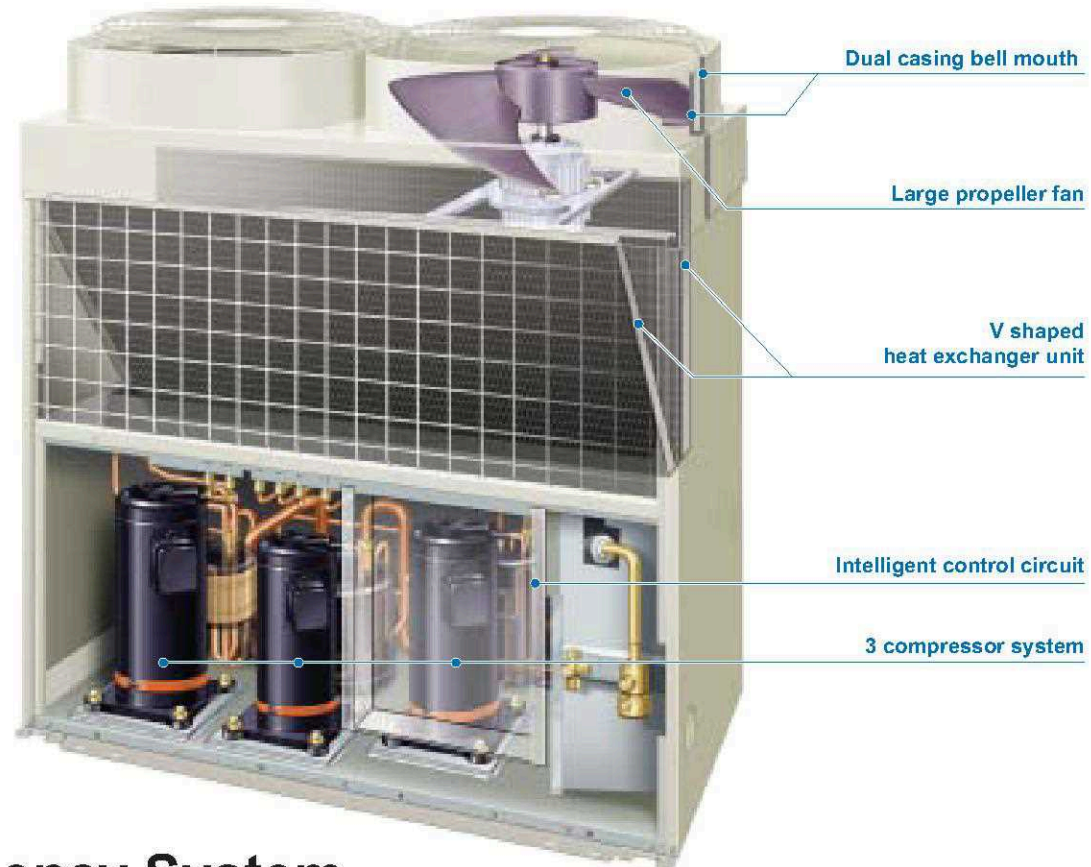

High Efficiency System

New operating system

The newly developed operating system controls the refrigerant flow rate inside the refrigerant circuit through the use of dual control technology, i.e. compressor capacity control technology and power balance control technology. This approach delivers high operating efficiencies through optimum refrigerant flow.

Cooling COP	3.10*
Heating COP	3.71*

* COP values are based on our own testing method. (AO90TPCMF)

Compressor Capacity Control

Compressor capacity control is achieved through the optimum balance of three individually rated compressors. This approach is extremely efficient as it provides a wide range of refrigerant flow rate options. Furthermore, by controlling the amount of gas "pumped" by each compressor, the system can accurately adjust refrigerant flow rates.

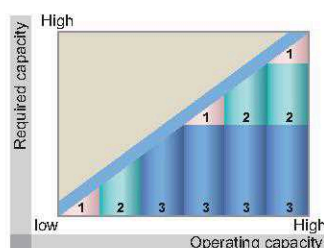

Power Balance Control

Power balance control technology achieves high operational efficiencies by detecting low pressure (evaporating temperature) during cooling and high pressure (condensing temperature) during heating and precisely controls the optimum refrigerant condition via refrigerant flow rate (capacity). Waste through excessive refrigerant flow is eliminated as is insufficient capacity due to insufficient refrigerant flow rate.

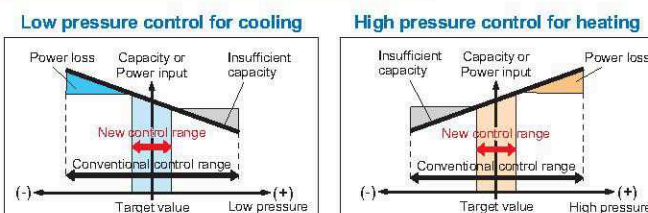
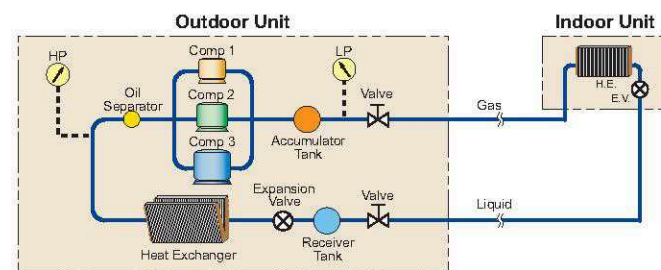

Web Monitoring Tool [Software]

Model : UTR-YMSA [Option]

Product features

Trouble-shooting is performed by monitoring each air conditioning unit remotely during periodical system checks.

Web Monitoring System

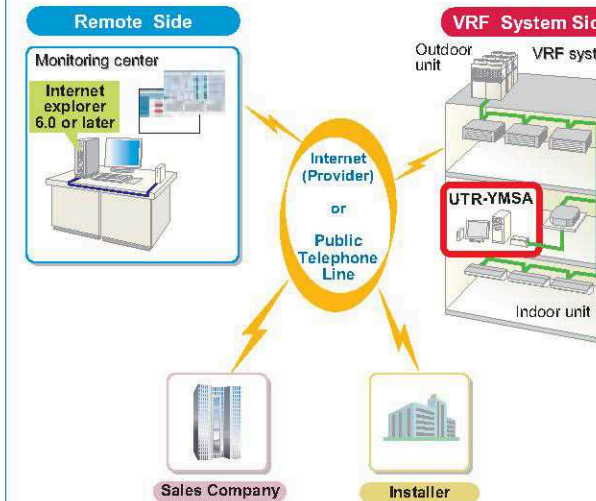

Features

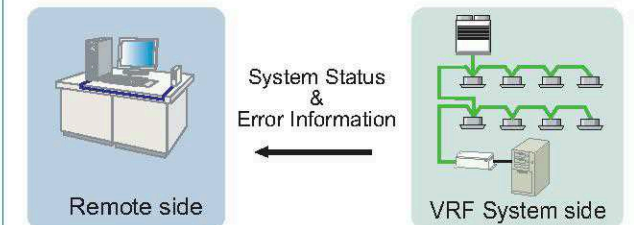

- Error notification can be automatically transmitted to several locations using the internet*.
- Requires either a dedicated internet connection* or public telephone line.
- Determination of an error occurrence can be made through error warnings and equipment status information obtained from a remote location.
- The monitoring data in a remote side can be optionally downloaded. And, this data can be displayed in off-line mode of the service tool.

* Unchanging global IP address is required.

Support 4 VRF system

PC Transmission adaptors (max. four adaptors per PC) permit control and monitoring of up to 1,600 units. Suitable for large-scale buildings or hotels.

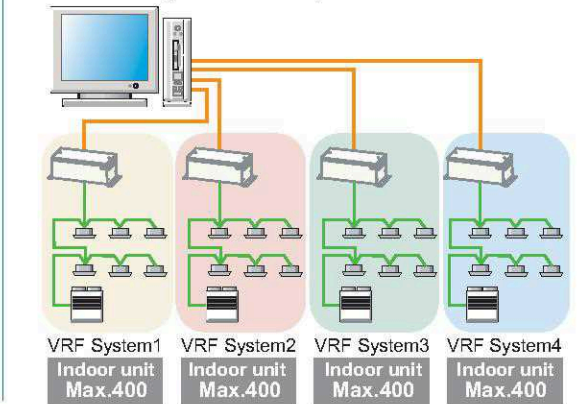

System components

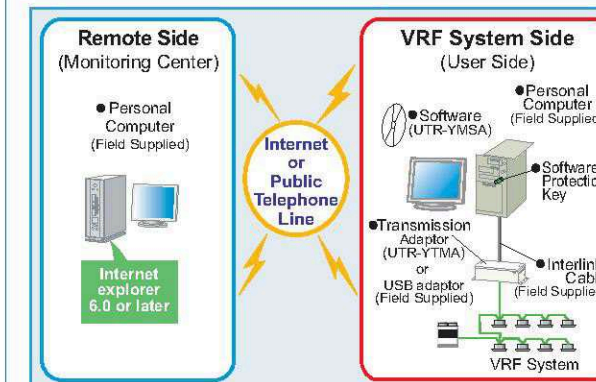

Requirements of PC for this software

Personal Computer	Operating System	AT compatible machine that runs Microsoft® Windows® · Microsoft® Windows® 2000 Professional (English version / Service pack3 or later) · Microsoft® Windows® XP Professional (English version / Service pack1 or later)
	CPU	Intel® Pentium® / Celeron®, AMD Athlon® / Duron™ 1GHz or higher
	HDD	2.1 GB or more
	Memory	512 MB or more
	Interface	Serial port (Max. 4)*1 and USB port
Software	Internet Explorer 6.0 or later / Adobe® Acrobat® Reader 4.0 or later *2	
Hardware	· Interlink cable D-sub 9pin [Field supplied] · Transmission Adaptor (UTR-YTMA)	

<PACKING LIST>

Packing List	CD-ROM / Software Protection Key
--------------	----------------------------------

*1 1 port required for each VRF system connected.

*2 If Internet Explorer is installed on the remote side PC, remote supervision of VRF system status is available.

Service Tool [Software]

Model : UTR-YSTC [Option]

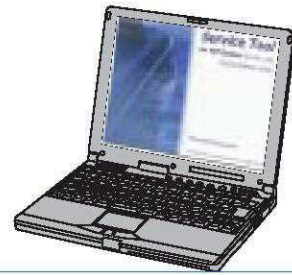

Standards in comfort and performance

HEAT PUMP & COOLING ONLY SERIES

Extensive monitoring and analysis functions for installation and maintenance

- Operational status can be checked and analyzed to detect even the smallest abnormalities.
- Storage of data on system operating status on a PC allows access even from off site.
- Up to 400 units (a single VRF system) can be controlled and monitored for large scale buildings or hotels.

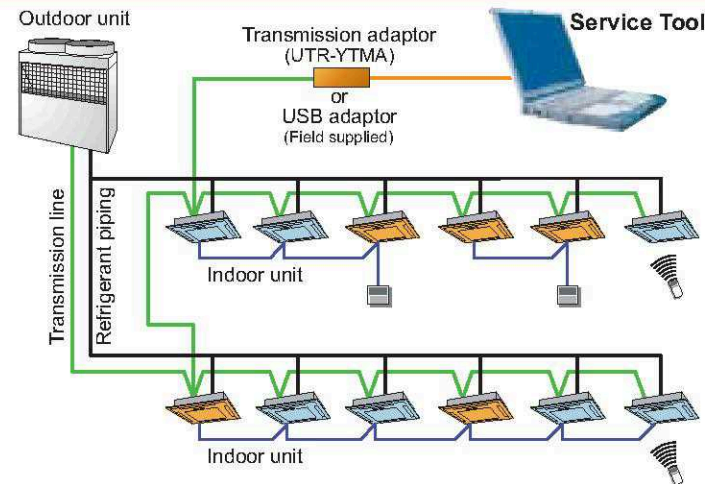

Functions

System list



Displays the overall operating status from a list of the status of each unit.

Equipment detail



Displays the schematic, sensor values, and electrical components operating status of the selected unit. Normal operation checks and cause specification when an error occurs are performed.

Commissioning tool

Test run commands can be executed with this tool. During test running, the outdoor unit/indoor unit sensor data can be saved (commissioning log data). After the end of test running, this data can be exported in CSV file format.

Error history



Displays the error information for each unit. The error information consequently display up to 50 items beginning from the newest error for each unit.

Requirements of PC for this software

Personal Computer	Operating System	AT compatible machine that runs Microsoft® Windows®
		Microsoft® Windows® 2000 Professional (English version / Service pack3 or later)
	CPU	Microsoft® Windows® XP Professional (English version / Service pack1 or later)
	HDD	Intel® Pentium® / Celeron®, AMD Athlon™ / Duron™ 1GHz or higher
	Memory	2.1 GB or more
	Interface	256 MB or more
Software		Serial port and USB port
Hardware		Internet Explorer 6.0 or later / Adobe® Acrobat® Reader 4.0 or later
		Interlink cable D-sub 9pin [Field supplied] / Transmission Adaptor (UTR-YTMA)

<PACKING LIST>

Packing List	CD-ROM / Software Protection Key
--------------	----------------------------------

Selectable Operation Mode

High power and energy saving

15% Energy saving

High power and energy saving modes are freely selectable and have the effect of varying the outlet air flow temperature by 2 degrees. The energy saving mode delivers 15% energy savings, whereas the high power mode increases capacity by an equal amount.

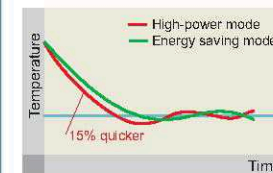

High power mode enables set point to be achieved much quicker (approx 15% faster).

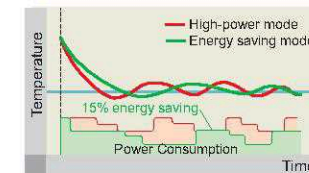

Energy saving mode discreetly adjusts room temperature to achieve a valuable 15% energy saving.

High Reliability

Recovery operation

Outdoor Unit

In the event of compressor failure an alarm is automatically triggered and the remaining compressor(s) will continue to operate, thereby ensuring continuous operation when possible.

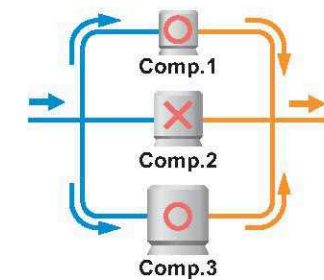

Indoor Unit

Each indoor unit operates independently from the others and is, therefore, not affected by a failure within any part of the network.

Oil Recovery operation

After a fixed period of time the oil recovery operation automatically returns accumulated oil found in the refrigerant circuit and indoor units.

Wide Operating Range

Cooling + heating operation at low outdoor temperature of down to -15°C

Outdoor unit operates over an outdoor temperature range of -15°C to 52°C for cooling and -15°C to 21°C for heating.

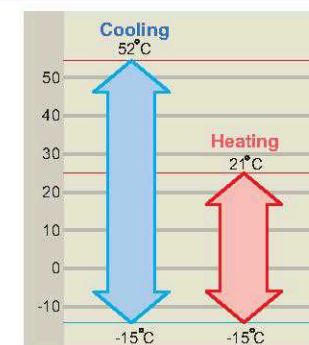

Super Quiet

Low sound pressure level

Operational noise has been reduced yet further through the application of a new dual casing bell-mouth and large fan. When set to silent operation, noise levels can be reduced by 5-6dB(A) compared to normal operation.

	28kW	22.4kW
Normal operation mode	55 dB(A)	54 dB(A)
Silent operation mode	50 dB(A)	48 dB(A)

(380V)

Surroundings Conscious

No Harmonic Disturbances

As our VRF system is not based on inverter technology to control refrigerant flow rate harmonic emissions are almost zero. As a result, it will not interfere with electronic equipment found in the office, factory or power distribution facilities, making it the ideal air conditioning solution for hospitals where harmonic emissions are strictly controlled.

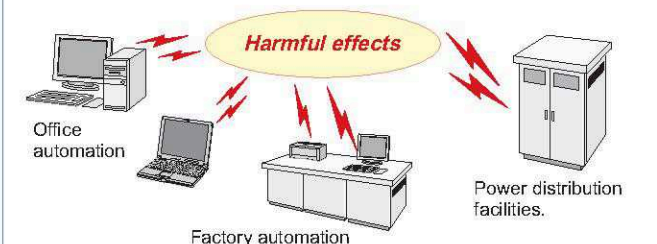

Maximum comfort from inbuilt flex

R407C Heat Recovery Type
AO90MPBMF(28kW)



High Efficiency System

Operating system

Cooling and heating can be performed simultaneously within the same refrigerant circuit. Energy savings are made by transferring heat between the indoor units when in heat recovery operation.

Cooling COP	2.98 [※]
Heating COP	3.15 [※]

※ COP values are based on our own testing method. (AO90MPBMF)

Smooth operation delivering high efficiencies

The configuration of 3 constant speed compressors with differing capacities and power accumulation technology ensure smooth step changes and highly efficient operation.

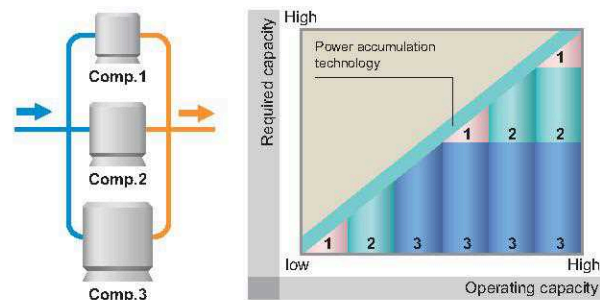

Flow rate between each step is controlled by power accumulation technology

Power Accumulation Technology

Flow rate to the indoor unit(s) is controlled through the use of 3 differently rated compressors operating in a sequential step arrangement. While power accumulation technology controls the circulating load of the refrigerant flow between those steps.

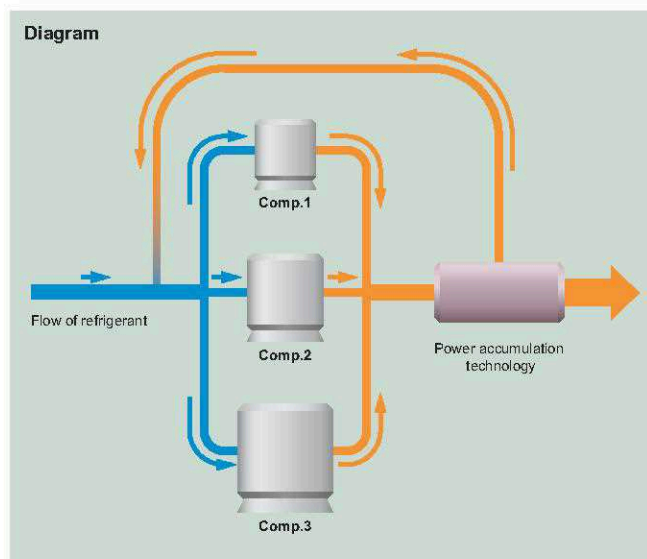

Wall Mounted Type (Compact) / Wall Mounted Type

Model	Wall Mounted Type (Compact)				Wall Mounted Type			
	AS7	AS9	AS12	AS14	AS18	AS24	AS30	
Power Source	220-240V-50Hz							
Cooling Capacity	kW	2.15	2.80	3.50	3.80	5.40	8.00	
	BTU / h	7,400	9,600	11,900	13,000	18,400	27,300	
Heating Capacity	kW	2.45	3.10	4.10	4.50	5.60	7.80	
	BTU / h	8,400	10,600	14,000	15,400	19,100	26,600	
Input	W	26	30	35	39	38	60	
Current	A	0.15	0.16	0.18	0.20	0.18	0.24	
Max. Current	A	0.18	0.19	0.22	0.24	0.22	0.34	
Air Circulation	High	410	450	520	540	840	1,050	
	Med	380	410	500	510	700	940	
	Low	350	370	470	490	600	780	
Fan Speed	High	1,000	1,090	1,250	1,300	1,080	1,320	
	Med	930	1,000	1,200	1,240	940	1,210	
	Low	860	900	1,150	1,180	810	1,030	
Fan Motor Output	W	16.5				38		
Noise Level (Sound Pressure)	High	30	33	37	38	42	48	
	Med	28	30	36	37	39	45	
	Low	26	27	34	35	35	42	
Fan Type x Q'ty	Cross Flow x 1							
Heat Exchanger	Plate Fin Coil							
Dimensions (H x W x D)	Net	257 x 808 x 187				320 x 1,120 x 220		
	Gross	270 x 850 x 310				348 x 1,240 x 427		
Weights	Net	8				16		
	Gross	10				22		
Pipe Size	Liquid	φ 6.35				φ 9.52		
	Gas	φ 9.52	φ 12.70		φ 15.88			
Pipe Connection Method	Flare							
Operation Range	Cooling	18 to 30						
	Heating	16 to 30						



Wall Mounted Type (Compact) indoor unit can't be operated in the Heat Recovery Type System.

Ceiling Wall Type

Model	Ceiling Wall Type							
	AW7	AW9	AW12	AW14	AW18	AW24	AW30	
Power Source	220-240V-50Hz							
Cooling Capacity	kW	2.15	2.80	3.60	4.30	5.40	8.00	
	BTU / h	7,400	9,600	12,300	14,700	18,400	27,300	
Heating Capacity	kW	2.45	3.10	4.10	4.90	5.60	7.80	
	BTU / h	8,400	10,600	14,000	16,700	19,100	26,600	
Input	W	16	19	20	21	30	50	
Current	A	0.08	0.09	0.10		0.14	0.19	
Max. Current	A	0.10	0.11	0.12		0.17	0.29	
Air Circulation	High	380	480	600	650	760	950	
	Med	330	420	520	570	660	870	
	Low	290	390	470	490	560	780	
Fan Speed	High	1,090	1,310	950	1,000	1,150	1,380	
	Med	980	1,180	860	910	1,030	1,280	
	Low	900	1,100	800	820	930	1,180	
Fan Motor Output	W	32						
Noise Level (Sound Pressure)	High	34	35		37	40	44	
	Med	32		33	35	37	41	
	Low	30	31		32	34	37	
Fan Type x Q'ty	Cross Flow x 1							
Heat Exchanger	Plate Fin Coil							
Dimensions (H x W x D)	Net	270 x 1,150 x 285						
	Gross	400 x 1,260 x 380						
Weights	Net	16						
	Gross	20						
Pipe Size	Liquid	φ 6.35				φ 9.52		
	Gas	φ 9.52	φ 12.70		φ 15.88			
Pipe Connection Method	Flare							
Operation Range	Cooling	18 to 30						
	Heating	16 to 30						

Note: Specifications are based on the following conditions.
Cooling: Indoor temperature of 27°CDB/19°CWB, and outdoor temperature of 35°CDB/24°CWB.
Heating: Indoor temperature of 20°CDB/15°CWB, and outdoor temperature of 7°CDB/6°CWB.



Specifications

High Static Pressure Duct Type

Model		High Static Pressure Duct Type		
		AR36H	AR45H	AR60H
Power Source		220-240V~50Hz		
Cooling Capacity	kW	10.5	12.7	17.0
	BTU / h	36,000	43,500	58,000
Heating Capacity	kW	10.7	13.7	17.6
	BTU / h	36,500	47,000	60,100
Input	W	445	463	733
Current	A	2.35		3.58
Max. Current	A	3.02		4.81
Air Circulation	High	2,000	2,200	3,000
	Med	1,700	1,900	2,750
	Low	1,400	1,600	2,500
Fan Speed	High	760	890	1,150
	Med	690	820	1,075
	Low	630	760	1,000
Fan Motor Output	W	350		500
Noise Level (Sound Pressure)	High	47	48	53
	Med	45	46	52
	Low	43	44	51
Fan Type x Qty	Sirocco x 2			
Heat Exchanger	Plate Fin Coil			
Dimensions (H x W x D)	Net	400 x 1,250 x 800		
	Gross	500 x 1,430 x 930		
Weights	Net	75		
	Gross	90		
Pipe Size	Liquid	φ 9.52		
	Gas	φ 19.05		
Pipe Connection Method	Flare			
Operation Range	Cooling	18 to 30		
	Heating	16 to 30		



Floor & Ceiling Universal Type / Ceiling Type

Model		Floor & Ceiling Universal Type					Ceiling Type		
		AB12	AB14	AB18	AB24	AB30	AB36	AB45	AB54
Power Source		220-240V~50Hz							
Cooling Capacity	kW	3.5	4.05	5.3	6.6	8.8	10.5	12.7	14.1
	BTU / h	11,900	13,800	18,100	22,500	30,000	36,000	43,500	48,200
Heating Capacity	kW	4.1	5.0	5.8	7.7	9.1	10.7	13.7	15.8
	BTU / h	14,000	17,100	19,100	26,300	31,000	36,500	47,000	54,000
Input	W	57		88	124	144	160	180	
Current	A	0.25		0.38	1.14	1.16	1.17		
Max. Current	A	0.30		0.45	1.36	1.39	1.40		
Air Circulation	High	640	770	900	1,620	1,890	2,110	2,350	
	Med	560	680	780	1,540	1,710	1,890	2,810	
	Low	480	560	660	1,360	1,450	1,630	1,900	
Fan Speed	High	850	1,030	1,180	850	1,000	1,100	1,250	
	Med	760	890	1,040	800	900	1,000	1,150	
	Low	670	770	900	700	750	850	1,000	
Fan Motor Output	W	16	30	40	160				
Noise Level (Sound Pressure)	High	40	46	49	41.5	47	50	52	
	Med	37	41.5	45	38	44	48	50	
	Low	34	37	41	34.5	39	44	46	
Fan Type x Qty	Sirocco x 2				Sirocco x 4				
Heat Exchanger	Plate Fin Coil								
Dimensions (H x W x D)	Net	199 x 990 x 655					240 x 1,660 x 700		
	Gross	320 x 1,150 x 790					318 x 1,800 x 790		
Weights	Net	28			30	48			
	Gross	37			39	61			
Pipe Size	Liquid	φ 6.35						φ 9.52	
	Gas	φ 12.70	φ 15.88			φ 19.05			
Pipe Connection Method	Flare								
Operation Range	Cooling	18 to 30							
	Heating	16 to 30							



Note : Specifications are based on the following conditions.
 Cooling : Indoor temperature of 27°CDB/19°CWB, and outdoor temperature of 35°CDB/24°CWB.
 Heating : Indoor temperature of 20°CDB/15°CWB, and outdoor temperature of 7°CDB/6°CWB.

Reliability

HEAT RECOVERY SERIES

Wide Operating Range

Cooling operation at outdoor temperatures down to -5°C

Outdoor unit operates over an outdoor temperature range of -5 °C to 52 °C for cooling and -15 °C to 21 °C for heating.

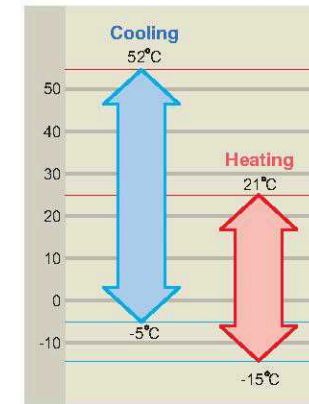

Super Quiet

Low sound pressure level

Operational noise has been reduced yet further through the application of a new dual casing bell-mouth and large fan. When set to silent operation, noise levels can be reduced by 5dB(A) compared to normal operation.

Normal operation mode	55 dB(A)
Silent operation mode	50 dB(A)

(380V)

Comfortable Operation

Heat Recovery operation

Heat Recovery operation is a cooling/heating free operation system, cooling and heating can be performed simultaneously in the same refrigerant system according to user needs. At the moment, The Heat Recovery operation is an extremely superior type that provides a still greater energy saving effect by moving heat between indoor units that are performing the cooling and heating operations. This is by having the compressors act like a pump.



High Reliability

Recovery operation

Outdoor Unit

In the event of compressor failure an alarm is automatically triggered and the remaining compressor(s) will continue to operate, thereby ensuring continuous operation when possible.

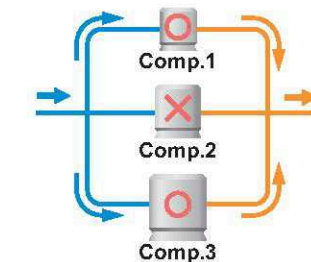

Indoor Unit

Each indoor unit operates independently from the others and is, therefore, not affected by a failure within any part of the network.

Oil Recovery operation

After a fixed period of time the oil recovery operation automatically returns accumulated oil found in the refrigerant circuit and indoor units.

Surroundings Conscious

No Harmonic Disturbances

As our VRF system is not based on inverter technology to control refrigerant flow rate harmonic emissions are almost zero. As a result, it will not interfere with electronic equipment found in the office, factory or power distribution facilities, making it the ideal air conditioning solution for hospitals where harmonic emissions are strictly controlled.

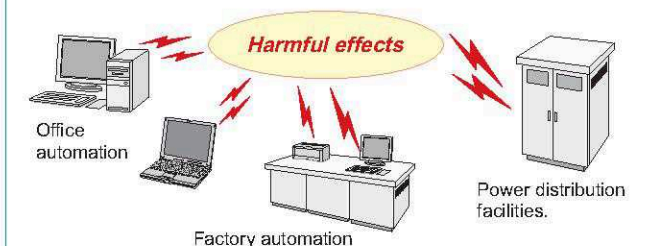

The VRF's quality features

Economical Operation

VRF differs from traditional ventilation and chiller systems being an economical multi air conditioning system that has the ability to exactly match air conditioning to the needs of the space.

Whether operating continuously as required within commercial buildings and public facilities or with large load variations for hotels, etc the VRF maintains optimum operation for that building. That means optimum comfort for the occupants at minimum energy expenditure.

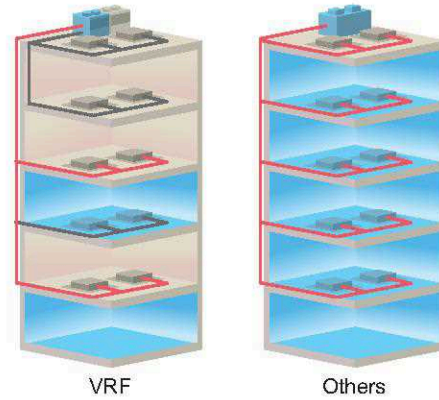

Easy Installation

System installation could not be easier, simply connect the refrigerant piping and data transmission line. Repositioning indoor units is just as easy.

Compact Size

Save space by installing in tandem.

Setting size **5.72** (Unit : m²)



Offering one of the smallest footprints available the outdoor unit provides 84kW(28kW x 3) capacity within a very tight space.

Free-up Valuable Space

The VRF allows the height difference between outdoor and indoor units to be as much as 50m. Consequently for a 15 storey building, for example, all of the outdoor units can be installed out of the way on the roof, freeing-up valuable interior space.

Easy Maintenance

VRF maintenance is easy and simple! Constant monitoring by a PC and integral software service tools can predict faults enabling the service engineer to rectify before a failure occurs.

Service Tool [Software] Model : UTR-YSTC



Service Tool monitors the entire VRF system.

Extensive monitoring and analysing functions.

- Operational status can be checked and analysed to detect even the smallest abnormality.
- By storing system operation status in a PC, data can be checked even when offline.

Cassette Type (Compact) / Cassette Type

Model	Cassette Type (Compact)						Cassette Type						
	AU7	AU9	AU12	AU14	AU18	AU20	AU25	AU30	AU36	AU45	AU54		
Power Source	220-240V-50Hz												
Cooling Capacity	kW	2.15	2.80	3.60	4.00	5.00	5.70	7.05	8.80	10.5	12.7	14.1	
	BTU / h	7,400	9,600	12,300	13,700	17,100	19,500	24,100	30,000	35,800	43,400	48,100	
Heating Capacity	kW	2.45	3.10	4.10	4.50	5.45	5.80	7.85	9.10	10.7	13.7	15.8	
	BTU / h	8,400	10,600	14,000	15,400	18,600	19,800	26,800	31,100	36,500	46,800	53,900	
Input	W	28		52		50	104	124	140	175	190	219	
Current	A	0.13		0.23		0.22	0.60	0.64	0.67	0.92	0.94	0.95	
Max. Current	A	0.15		0.27		0.26	0.72	0.77	0.80	1.10	1.12	1.14	
Air Circulation	High	530		580		640	1,000	1,100	1,200	1,500	1,650	1,780	
	Med	480		520		540	840	940	1,050	1,300	1,450	1,550	
	Low	410		460		470	700	780	840	1,100	1,200	1,300	
Fan Speed	High	630		690		750	450	490	540	580	620	680	
	Med	570		610		640	390	430	480	500	550	580	
	Low	480		540		540	330	360	390	420	470	500	
Fan Motor Output	W	9		10		15	42			90			
Noise Level (Sound Pressure)	High	38		41		44	42	44	46	48	49	52	
	Med	35		37		38	38	42	44	44	47	48.5	
	Low	31		34		35	35	39	41	41	43	45	
Fan Type x Q'ty	Turbo x 1												
Heat Exchanger	Plate Fin Coil												
Dimensions (H x W x D)	Net	230 x 570 x 570				246 x 830 x 830			296 x 830 x 830				
	Gross	280 x 710 x 750				385 x 1,045 x 1,015			435 x 1,045 x 1,015				
Weights	Net	18				34			40				
	Gross	23				45			53				
Pipe Size	Liquid	φ 6.35						φ 9.52					
	Gas	φ 9.52		φ 12.70		φ 15.88			φ 19.05				
Pipe Connection Method	Flare												
Operation Range	Cooling	18 to 30											
	Heating	16 to 30											

Duct Type (Compact) / Duct Type

Model	Duct Type (Compact)					Duct Type					
	AR7	AR9	AR12	AR14	AR18	AR25	AR30	AR36	AR45		
Power Source	220-240V-50Hz										
Cooling Capacity	kW	2.15	2.80	3.50	4.00	5.30	7.05	8.80	10.5	12.7	
	BTU / h	7,300	9,600	11,900	13,700	18,100	24,100	30,000	36,000	43,500	
Heating Capacity	kW	2.45	3.10	4.10	4.80	5.60	7.85	9.10	10.7	13.7	
	BTU / h	8,400	10,600	14,000	16,400	19,100	26,800	31,000	36,500	47,000	
Input	W	40	43	34	50	62	155	240	265	315	
Current	A	0.21		0.20	0.23	0.27	0.68	1.06	1.16	1.44	
Max. Current	A	0.25		0.24	0.27	0.32	0.84	1.58	1.58	1.84	
Air Circulation	High	340	420	460	640	750	1,200	1,650	2,000	2,200	
	Med	320	390	430	560	700	1,100	1,550	1,800	2,000	
	Low	290	360	390	480	640	1,000	1,350	1,600	1,800	
Fan Speed	High	780	960	640	840	960	890	1,240	1,280	1,320	
	Med	720	880	610	740	900	820	1,140	1,200	1,270	
	Low	660	810	580	650	840	745	1,040	1,130	1,200	
Fan Motor Output	W	12	14	16	18	21	70	275			
Noise Level (Sound Pressure)	High	31	35	28	34	36	44	47		49	
	Med	28	33	27	32	35	42	45		47	
	Low	26	31	26	30	33	40	43		45	
Fan Type x Q'ty	Sirocco x 1					Sirocco x 2					
Heat Exchanger	Plate Fin Coil										
Dimensions (H x W x D)	Net	217 x 663 x 595			217 x 953 x 595			270 x 1,210 x 700			
	Gross	324 x 785 x 686			324 x 1,075 x 686			300 x 1,300 x 790			
Weights	Net	18			25			43		45	
	Gross	22			29			53		55	
Pipe Size	Liquid	φ 6.35					φ 9.52				
	Gas	φ 9.52		φ 12.70		φ 15.88			φ 19.05		
Pipe Connection Method	Flare										
Operation Range	Cooling	18 to 30									
	Heating	16 to 30									

Note : Specifications are based on the following conditions.
 Cooling : Indoor temperature of 27°CDB/19°CWB, and outdoor temperature of 35°CDB/24°CWB.
 Heating : Indoor temperature of 20°CDB/15°CWB, and outdoor temperature of 7°CDB/6°CWB.

Specifications

Heat Pump / Cooling Only Type			Refrigerant Type : R407C				Refrigerant Type : R22			
Model			AO90 TPCMF	AO72 TPCMF	AO90 EPCMF	AO72 EPCMF	AO90 RPCMF	AO72 RPCMF	AO90 APCMF	AO72 APCMF
Power Source			3 phase, 380 - 415V, 50Hz							
Total Capacity	Cooling	kW	28.0	22.4	28.0	22.4	28.0	22.4	28.0	22.4
	Heating		31.5	25.2	—	—	31.5	25.2	—	—
Total Input Watts	Cooling	kW	9.03	7.23	9.03	7.23	9.03	7.23	9.03	7.23
	Heating		8.50	7.64	—	—	8.50	7.00	—	—
E.E.R.	Cooling	W/W	3.10							
	Heating		3.71	3.30	—	—	3.71	3.60	—	—
Heat Exchanger			Plate Fin Coil							
Fan Speed	High	r.p.m.	730							
	Low		360							
Air Circulation	High	m ³ /h	9800							
Fan Type x Qty			Propeller x 2							
Fan Motor Output			W							
Compressor	Motor Output	kW	1.5/3.4/4.9	1.5/2.5/4.8	1.5/3.4/4.9	1.5/2.5/4.8	1.5/3.7/5.0	1.5/2.5/4.8	1.5/3.7/5.0	1.5/2.5/4.8
	Protection		Internal Protector(OCR) / High Pressure Relief Valve							
Dimensions(H x W x D)	Net	mm	1,380 x 1,300 x 650							
	Gross		1,535 x 1,400 x 770							
Weights	Net	kg	313	307	312	306	323	307	320	304
	Gross		349	343	348	342	359	343	356	340
Noise Level (Sound Pressure)	380V	dB (A)	55	54	55	54	55	54	55	54
	415V		57	56	57	56	57	56	57	56
Refrigerant	Type	kg	R407C				R22			
	Charge		10	9	10	9	10	9	10	9
Pipe	Size	Liquid	φ 12.70							
		Suction Gas	φ 28.58							
	Max Length	100								
	Max Height	50								
Operation Range (Outdoor)	Cooling	°C	-15 to 52				21 to 52			
	Heating		-15 to 21				-15 to 21			



Heat Recovery Type			Refrigerant Type : R407C			
Model			AO90MPBMF			
Power Source			3 phase, 380 - 415V, 50Hz			
Total Capacity	Cooling	kW	28.0			
	Heating		31.5			
Total Input Watts	Cooling	kW	9.40			
	Heating		10.0			
E.E.R.	Cooling	W / W	2.98			
	Heating		3.15			
Heat Exchanger			Plate Fin Coil			
Fan Speed	High	r.p.m.	730			
	Low		360			
Air Circulation	High	m ³ /h	9,800			
Fan Type x Qty			Propeller x 2			
Fan Motor Output			W			
Compressor	Motor Output	kW	1.5 / 3.4 / 5.0			
	Protection		Internal Protector (OCR) High Pressure Relief Valve			
Dimensions (H x W x D)	Net	mm	1,380 x 1,300 x 650			
	Gross		1,535 x 1,400 x 770			
Weights	Net	kg	313			
	Gross		350			
Noise Level (Sound Pressure)			dB (A)			
Refrigerant	Type	kg	R407C			
	Charge		13			
Pipe	Size	Liquid	φ 12.70			
		Discharge Gas	φ 19.05			
	Suction Gas	φ 28.58				
	Max. Length	100				
Operation Range (Outdoor)	Max. Height	50				
	Cooling	°C	-5 to 52			
Heating	-15 to 21					



Note : Specifications are based on the following conditions.
Cooling : Indoor temperature of 27°CDB/19°CWB, and outdoor temperature of 35°CDB/24°CWB.
Heating : Indoor temperature of 20°CDB/15°CWB, and outdoor temperature of 7°CDB/6°CWB.

HEAT PUMP & COOLING ONLY SERIES

HEAT RECOVERY SERIES

Flexible Construction

Infinitely variable selection from 12 different types and 45 models of indoor unit plus 9 outdoor units. The outdoor unit is capable of handling 130% capacity, easily accommodating future system changes and expansion.

System upgrade network parts

*See details on page 38.



Network Converter

Model : UTR-YRDA (Option)

This network convertor is to be used for connecting single split system or group remote controller with the VRF system.



Network Converter (LONWORKS®)

Model : UTR-YLLA (Option)

By using the UTR-YLLA, the VRF system can be centrally controlled or monitored from a BMS with a LONWORKS® interface.

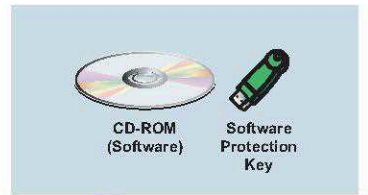

BACnet®Gateway [Software]

Model : UTR-YLBA

The central control of maximum 1600 indoor units can be realized by connecting the VRF system to the BACnet®, a global standard of the open network

Comparison with the features between VRF and other system

		VRF system	Other system
Basic	Heat Transfer Media	Refrigerant	Water
	Heat Carrying Capacity	49 kcal/kg (10 times higher than chiller)	5 kcal/kg
Energy Saving	Energy Efficiency	High Energy Efficiency Direct heat transfer from refrigerant to room air	Less Energy Efficiency 1st. stage heat transfer : From refrigerant to water 2nd. stage heat transfer : From water to room air
	Overall Heat Transfer Efficiency	High Between refrigerant & room air	Low Between water & room air
	Operation Time	Short (To reach set room temperature)	Long (To reach set room temperature)
	Energy Transmission Loss	Low Heat loss through connecting pipe from outdoor unit to indoor unit	High Heat loss through connecting pipe from chilled water unit to indoor fan coil unit
	System Efficiency (Partial Load Operation)	High (Refrigerant flow reduced due to compressor power reduction)	Low Compressor power consumption reduced but constant water circulation pump consumption
Additional Benefits	Heating Operation Performance (Below 0°C)	Sufficient (Discharge air temperature from indoor unit above 37°C)	Insufficient (Except connecting water heating boiler)
	Flexibility (Choice of Fan coil Unit)	More Flexible	Less Flexible
	Maintenance	simpler and easier than "other systems"	Periodic

Note: "Other system" means water chiller system.

For consultants and building des

The VRF system offers an infinitely variable choice of indoor and outdoor units: 12 types and 45 models of indoor units together with a choice of 9 outdoor units. Plus 2-pipe (heat pump, cooling only) and 3-pipe (heat recovery) systems are available providing inbuilt reliability. VRF offers flexible and quick air conditioning design solutions supported by low running and maintenance costs, particularly when compared to conventional systems.

INDOOR UNIT

Design Flexibility

Shorten the design time

Compared to conventional building air conditioning systems, VRF system design is fast thanks to the simplicity of the outdoor unit, refrigerant piping and data transmission - and the VRF can control up to 100 outdoor units and 400 indoor units. Refrigerant piping between outdoor and indoor units can extend up to 100m in length with a height difference of 50m, making 15-storey buildings easy to accommodate. So, system design is uncomplicated and fast.

Long piping for high-rise buildings

Vertical lift between outdoor unit and indoor units : 50m maximum.

※When outdoor unit is located above indoor unit.

When outdoor unit is located below the indoor unit the height difference is 40m maximum.

Vertical lift between indoor unit and indoor units : 15m maximum.

Actual pipe length : 100m maximum.

Equivalent pipe length : 120m maximum.

Total pipe length : 200m maximum.

Heat Pump / Cooling Only Heat Recovery

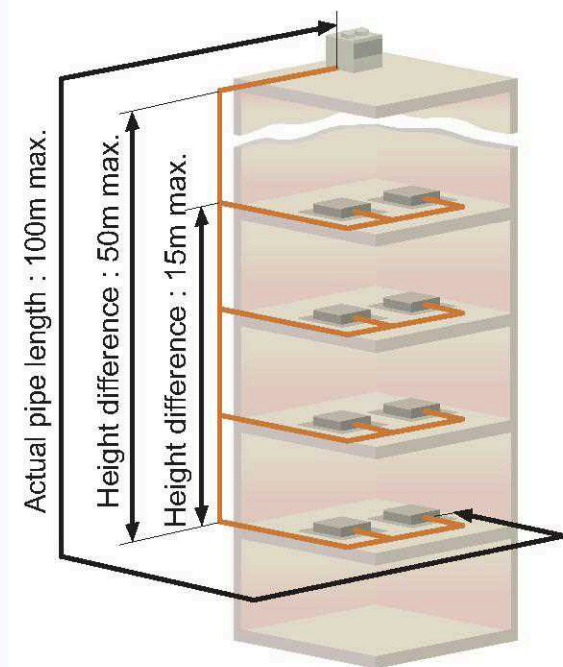

- Equivalent pipe length: 120m maximum.
- Total pipe length: 200m maximum.

Maximum number of connectable indoor units

One outdoor unit can control up to 16 indoor units (28kW) or 13 indoor units (22.4kW) of different types and capacities.

Type	Capacity	Refrigerant		Max. connectable indoor unit
		R407C	R22	
Heat Recovery	28.0kW	AO90MPBMF	—	16
	28.0kW	AO90TPCMF	AO90RPCMF	16
Heat Pump	22.4kW	AO72TPCMF	AO72RPCMF	13
	28.0kW	AO90EPCMF	AO90APCMF	16
Cooling Only	22.4kW	AO72EPCMF	AO72APCMF	13

Connectable capacity of indoor units for one outdoor unit **50 to 130%**

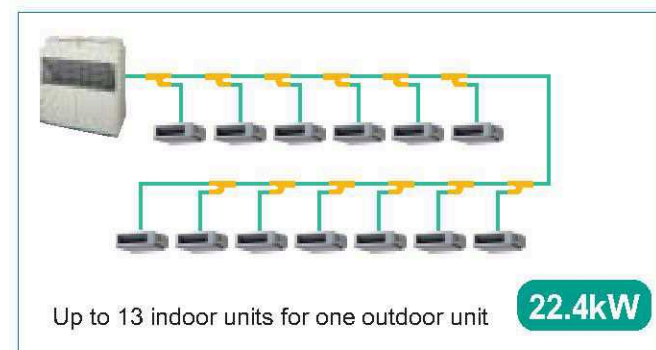
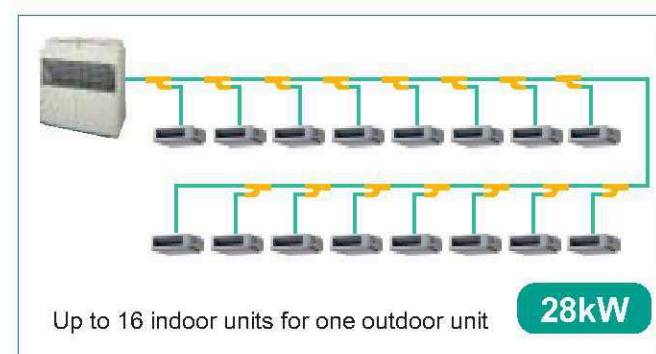

'Double auto swing' feature provides omni-directional air flow control.

Wall Mounted Type

Models

AS18 / AS24 / AS30

Features

Multi air flow

Large independently driven power diffuser used

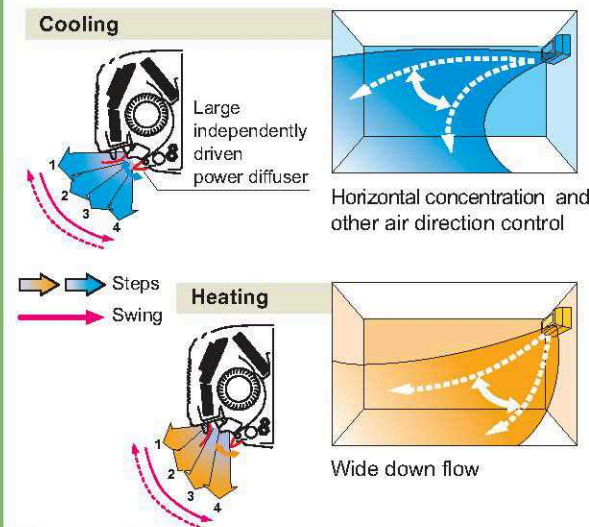

Low noise

- High efficiency fan construction
- $\phi 7$ mm Lambda type evaporator improves the airflow path
- Large independently driven power diffuser

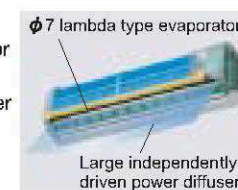

Easy installation

Larger space at base of housing means extra 15% piping space.

Others

- Other features include continuation of the functions of the existing wall mounted type.
- Double auto swing
- 2-way draining route



Attractive housing with discreet air intake.

Ceiling Wall Type

Models

AW7 / AW9 / AW12 / AW14 / AW18 / AW24 / AW30

Features

High efficiency

High output and high efficiency are achieved by using a DC motor.

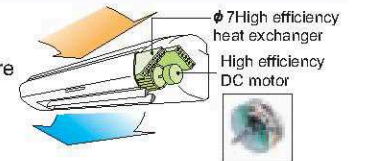

Larger, wider airflow

Introduction of the top air intake reduces the curvature of the air flow path thereby achieving lower air resistance, lower noise and larger air volume.

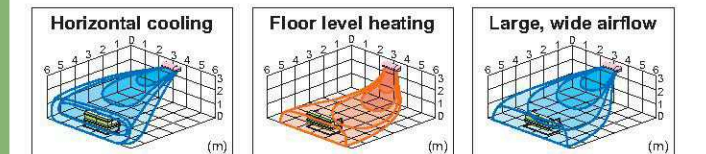

Easy maintenance

Drain pan can be easily removed for thorough washing without re-moving the unit from the wall.

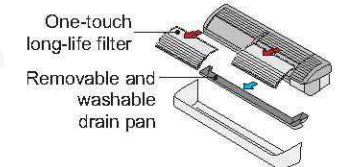

Low noise

Suppressing the turbulence by providing vertical grooves on the quiet louver and the right/left louver reduces annoying noise.



Long-life filter

- Long-life filter can be removed with one touch.
- Long-life filter extends the cleaning cycle by a factor of three.

Others

- Double auto swing/Right and left, up and down
- 2-way draining route
- Air purifying filter (Optional parts)

Ceiling / Wall Mounted (Compact) / Wall Mounted / Ceiling Wall Type **igners**

HEAT PUMP & COOLING ONLY SERIES

HEAT RECOVERY SERIES



An ultra-slim design that offers a variety of installation methods, this indoor unit is lightweight and extremely quiet.

Ceiling Type

Models

AB30 / AB36 / AB45 / AB54

Features

Installation

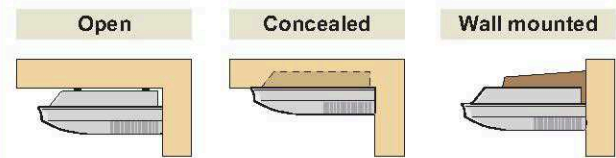

Condensate lift-up mechanism

Optional drain lift-up mechanism allows flexible installation.

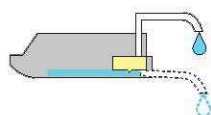

Double auto swing and wide air flow

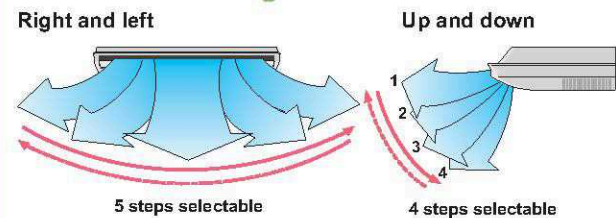

Fresh air intake

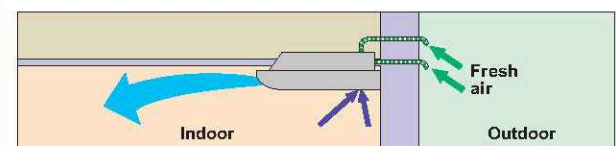

Long-life filter

High efficiency, long-life filter extends the cleaning cycle by a factor of two.

Optional parts

Drain water riser kit UTR-DPB241



Stylish and compact, these elegant wall-mounted units complement any interior decor

- This indoor unit can't be operated in the Heat Recovery Type System.
- AS7/AS9/AS12/AS14 are only available for wireless remote controller.

Wall Mounted Type (Compact)

Models

AS7 / AS9 / AS12 / AS14

Features

Compact design

Powerful output despite small size

This compact wall mounted units have a powerful cooling capacity due to the large high pressure fan and lambda type heat exchanger.



Low noise level

The aerodynamic characteristics of the outlet louver contribute to a very quite indoor unit.

Fan speed	dB(A)
HIGH	30
LOW	26

(AS7)

Auto swing louver

The "Auto Swing Louver" feature ensures optimum airflow for each of the operating modes.

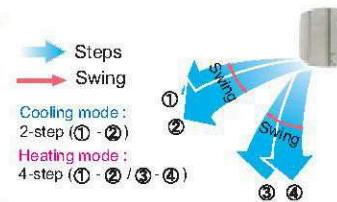

Washable panel filter

The removable and washable panel filter is an effective "air cleanser" removing mould and dust from the occupied environment.

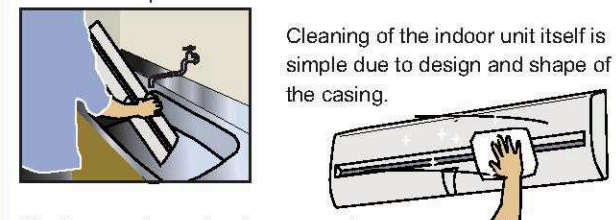

The top panel can also be removed for easy cleaning if necessary.

Flexible Control System

Flexible design

Flexibility is enhanced through the ability to connect outdoor units, indoor units and controllers anywhere within the data transmission line.

Maximum connectable number per one transmission line

Refrigerant system	100
Indoor units	400
Outdoor units	100

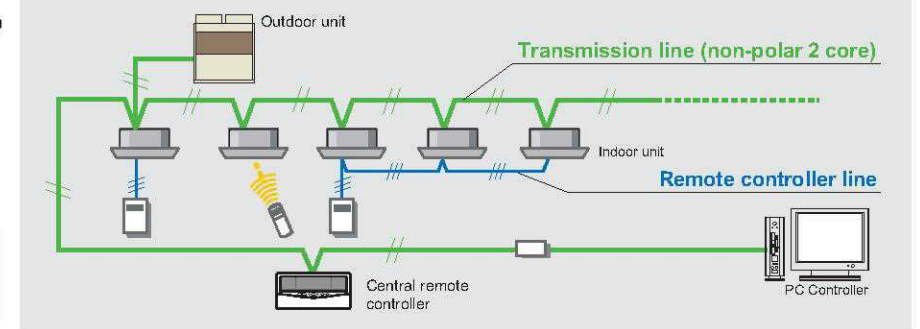

Control options

A variety of control options are available within one VRF system. As the signal receiver is built into the indoor unit a mix of wired/simple/wireless remote controllers can be used simultaneously with the same indoor unit.

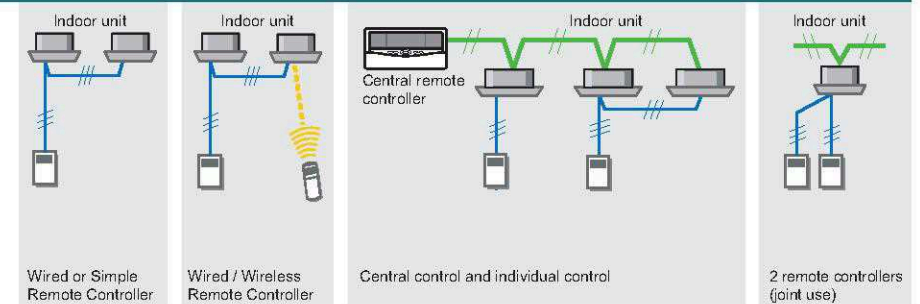

Group control

This function is used when operating multiple remote controller groups at one time from a central remote controller or PC controller.

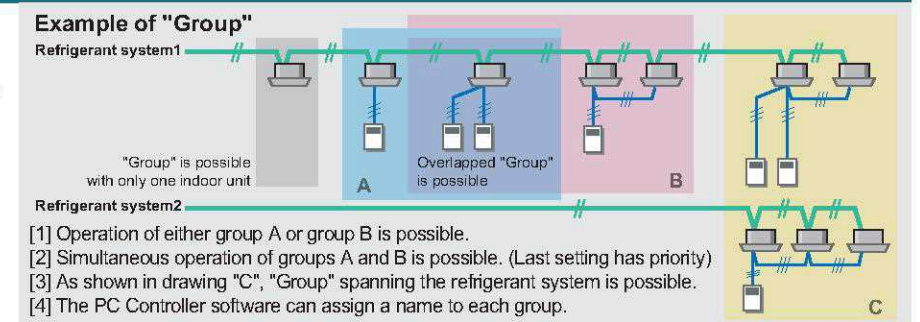

Advanced Functions

Interfacing system with external equipment

An output on the indoor PCB allows an auxiliary fan to be connected, possible to introduce outdoor air etc.

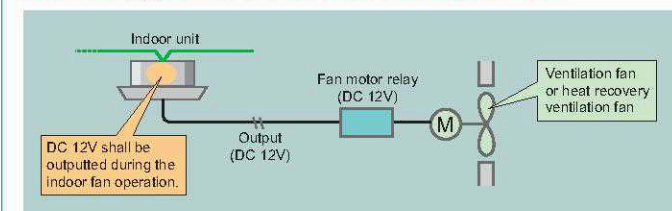

Emergency turn off

Function for emergency turn off in case of fire or earthquake, etc.

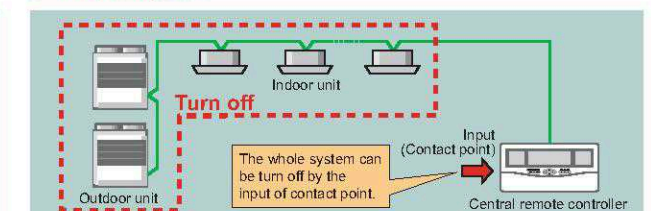

For Installers

Reduced Installation Work

Compact size

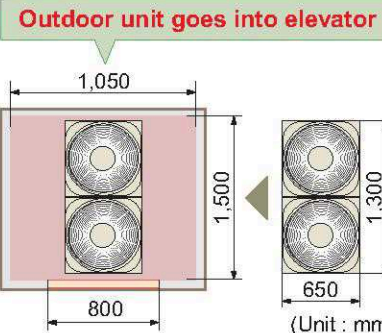
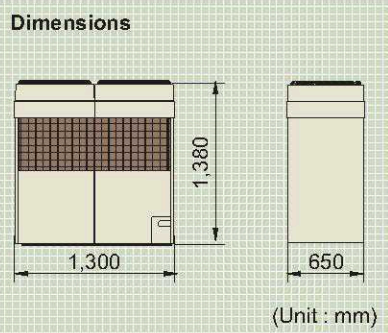

Space saving

Space saving by setting side by side without space in between.

Setting size **5.72 (Unit : m²)**



Offering one of the smallest footprints available the outdoor unit provides 84kW (28kW x 3) capacity within a very tight space.

Installation space

For individually

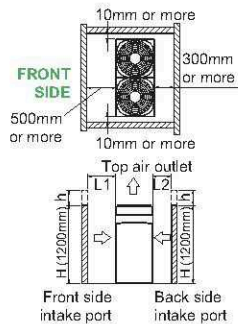

For continuous

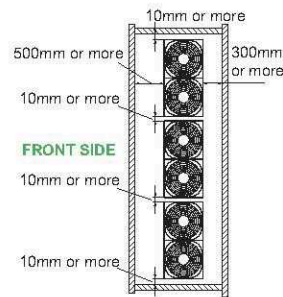

- There is no height restriction for the side wall.
 - The height(H) of front and rear wall should be less than 1,200mm.
 - If the height of wall exceeds 1,200mm by h mm, add h mm to the service space width for L1 and L2.
- $H \leq 1,200$: $L1 \geq 500$, $L2 \geq 300$
 $H > 1,200 + h$: $L1 > 500 + h$, $L2 > 300 + h$

Craning into place

The outdoor unit can be lifted by crane and set down on the building roof.

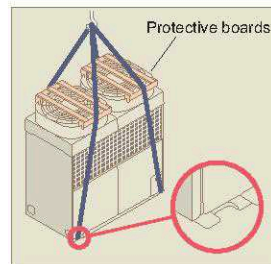

Piping connection

Four-direction piping allows a variety of installation configurations. Easy installation and pipe direction setting.

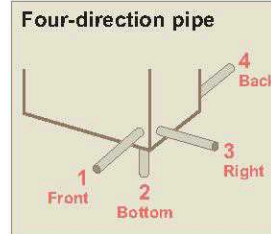

Low Piping Costs

Simple piping system

The simple piping system reduces costs by increased piping flexibility.

Cooling Only & Heat Pump

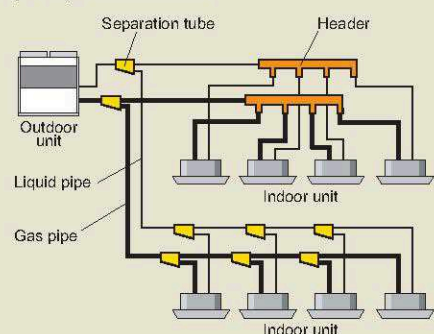

Heat Recovery

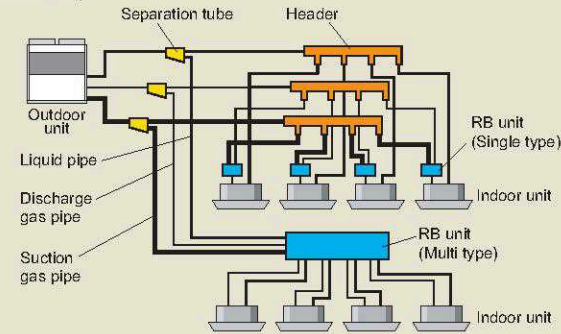

versal Type

INDOOR UNIT



A high static pressure duct type indoor unit

High Static Pressure Duct Type

Models

AR36(H) / AR45(H) / AR60(H)

Features

Savings in space and reduction in noise

Installed in the ceiling void this model provides savings in space and reductions in noise.

A single indoor unit can serve several rooms.

Easy installation

The pipe can be connected in any direction by using the L-shaped auxiliary pipe.

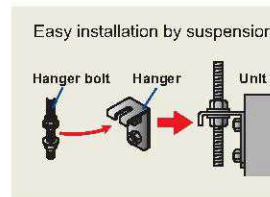
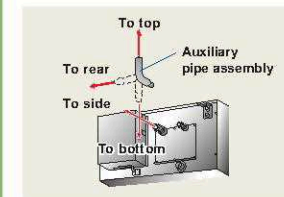

Easy maintenance

Fan motor maintenance can be performed from the top and the bottom.

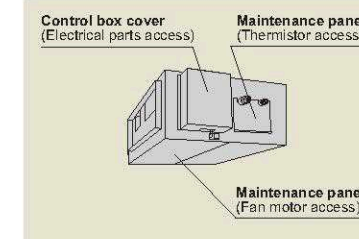
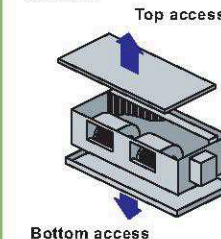

High static pressure

Recommended external static pressure : 196 Pa (Max. 300Pa)

Optional parts

Outlet chamber	UTD-BC200
Flexible duct	UTD-RD202
Long life filter	UTD-LF400
Remote sensor unit	UTD-RS100



The slim and lightweight design allows the unit to be suspended from the ceiling or installed at floor level.

Floor & Ceiling Universal Type

Models

AB12 / AB14 / AB18 / AB24

Features

Flexible installation

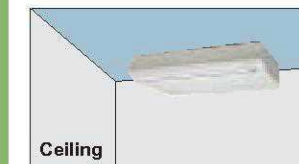

Compact design

Symmetrical, slim and compact design



Double auto swing

A combination of up/down and right/left directional swing allows three-dimensional air direction control.

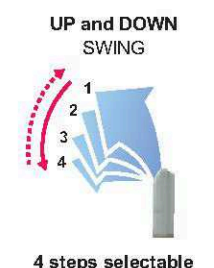
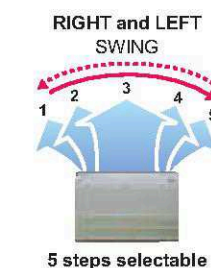

Super vane

Double-flap 'Super Vane' with newly developed special configuration boosts air flow sending cool air quickly to every corner of the room.

Auto-closing louver

This function is common to all indoor unit types except the duct type.

Duct (Compact) / Duct / High Static Pressure Duct / Floor & Ceiling Uni

HEAT PUMP & COOLING ONLY SERIES

HEAT RECOVERY SERIES



Choice of installation
Can be suspended from the ceiling or placed on the floor

Duct Type (Compact)

Models

AR7 / AR9
AR12 / AR14 / AR18

Features

Compact design

Ultra-slim duct air conditioner for easy installation



Easy to install (Universal type)

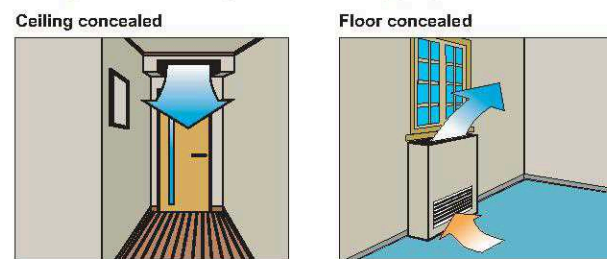

Low noise level

A low noise level has been achieved for each capacity

Model		7	9	12	14	18
Static pressure (Normal/Max.)	Pa			0 / 39.6		
Volume of air-flow (High/Low)	m ³ / h	340/290	420/360	460/390	640/480	750/640
Noise level (Low speed)	dB(A)	26	31	26	30	33

Optional parts

Remote sensor unit UTD-RS100



Ultra-slim duct air conditioner for very low ceilings

Duct Type

Models

AR25 / AR30 / AR36 / AR45

Features

Savings in space and reduction in noise

Whether installed in the ceiling void or a false ceiling, this model provides savings in space and reductions in noise. A single indoor unit can serve several rooms.

Flexible installation

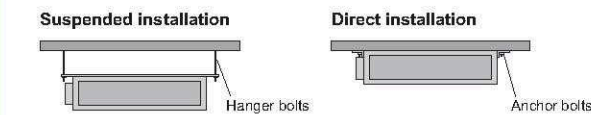

Installation styles

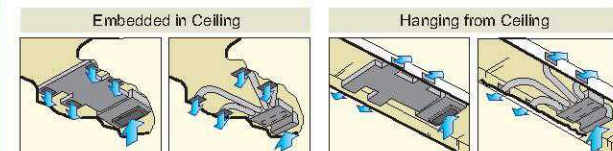

Ultra-slim models for very low ceilings



Piping can be run in almost any direction

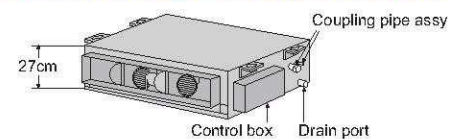

Optional parts

Flange (square)	UTD-SF045T
Flange (round)	UTD-RF204
Flexible duct	UTD-RD202
Long life filter	UTD-LF270
Remote sensor unit	UTD-RS100

Easy Wiring

Transmission line

Non-polar 2-conductor transmission line prevents erroneous wiring.

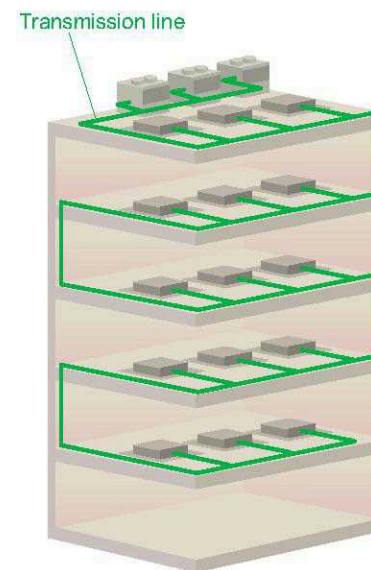

Power supply wiring

Power supply for outdoor and indoor units is different.

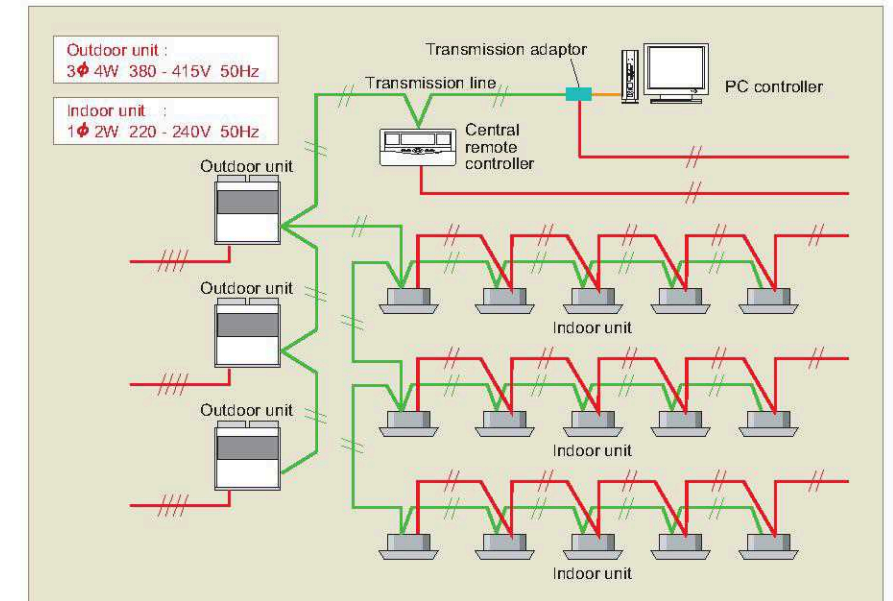

Service Tool [Software] Model: UTR-YSTC

Service Tool can monitor the operation of the entire VRF system.

Extensive monitoring and analysing functions

- Operational status can be checked and analysed to detect even the smallest abnormality.
- By storing system operation status in a PC, data can be checked even when offline.



Easy Maintenance

Operating display (outdoor unit)

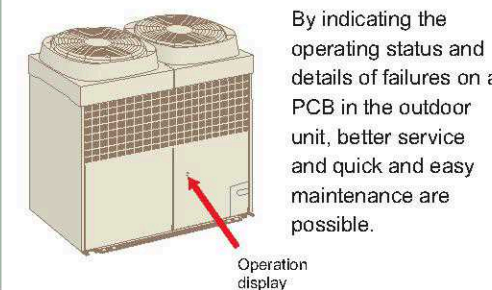

By indicating the operating status and details of failures on a PCB in the outdoor unit, better service and quick and easy maintenance are possible.

Easy replacement

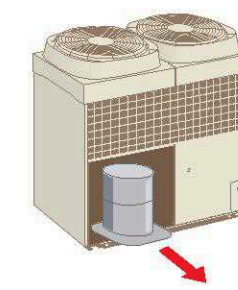

A pull-out plate ensures easy compressor replacement if necessary.

Pump down control

Pump down can be performed from the outdoor unit using the switch on the PCB.

VRF structure and features ensure



Flexible Control System

Features of control system

1. Reduced wiring as all system equipment accommodated on a single transmission line (non-polar 2-conductor).
2. Total wiring length (total length of transmission line) can be extended up to 2000m (by using signal amplifier units).
3. Maximum of 400 indoor units can be connected.
4. Indoor units can be controlled by wired, simple, wireless, group, central remote controller or PC controller.
5. Central control of single split type models (with exceptions) or big multi type air conditioners is possible from a central remote controller or PC controller.
6. Model combinations are dictated by the building's needs and not the system.
7. The 'simple' remote controller is ideal for installations such as hotel guest rooms.

Control system reliability

1. Individual operation of the indoor units ensures that the failure of one does not affect the whole system.
2. Maintenance efficiencies are raised through the connection of a PC anywhere on the data transmission line.
3. Error codes can be clearly displayed on the wired remote controller, simple remote controller, group remote controller, central remote controller or PC controller.

Configuration of control system

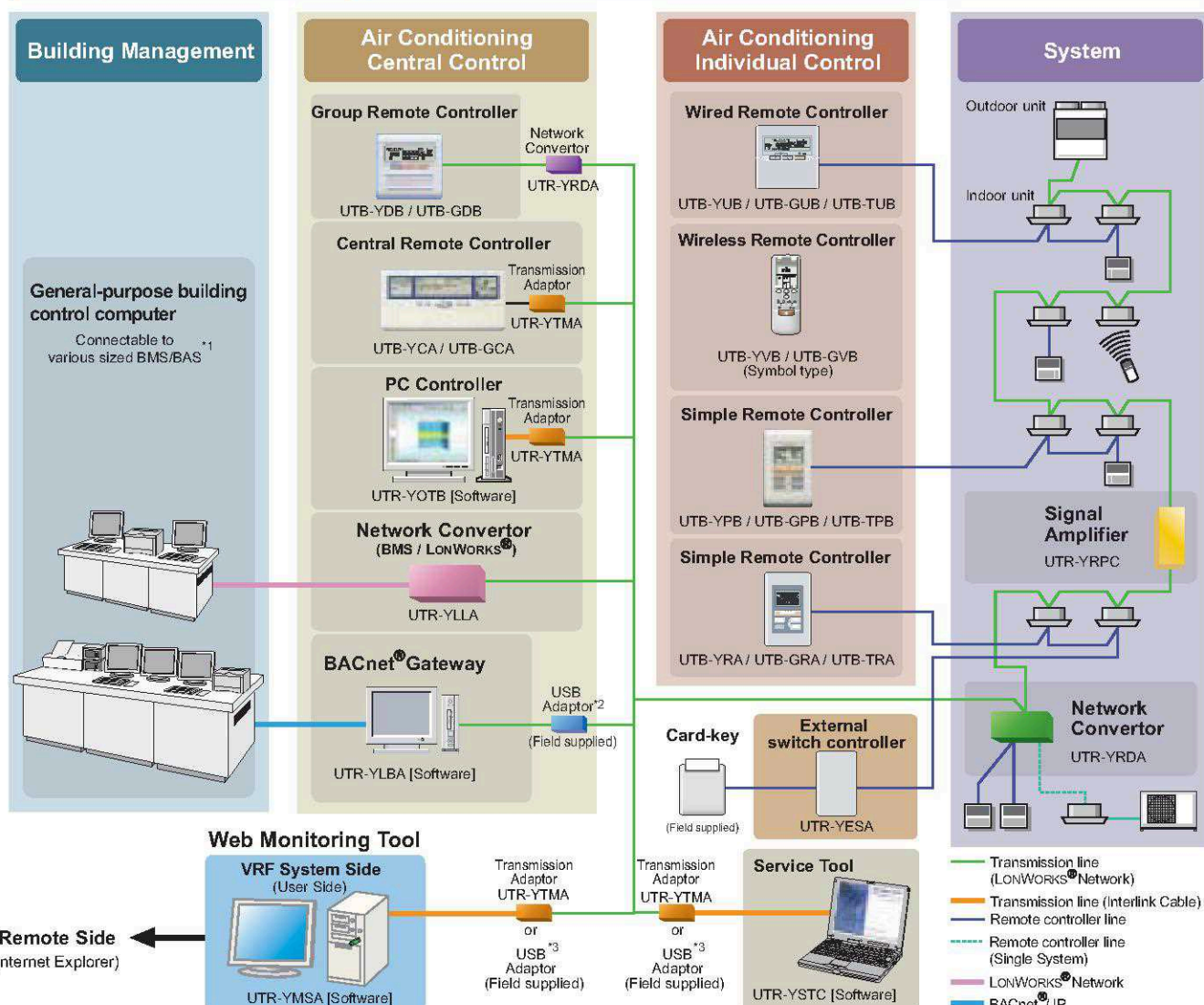

*1. BMS/BAS: Building Management System / Building Automation System. Building Management System is supplied by the other vendors.
 *2. USB Adaptor is XLON® USB Adaptor of DH electronics company.
 *3. U10 USB Network Interface - TP/FT-10 (Echelon corporation)



Slim cassette, designed for limited ceiling space

Cassette Type

Models

AU20 / AU25 / AU30 **Slim Type**
 AU36 / AU45 / AU54

Features

Flexible installation

Compact body ensures space saving installation. A slender fit option is available where ceiling void space is limited.

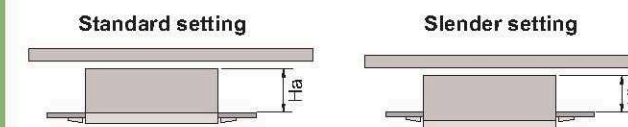

	Standard setting	Slender setting
AU20 / AU25 / AU30	Ha	Hb
AU36 / AU45 / AU54	285	250

Easy maintenance



Condensate pump lift to 800mm

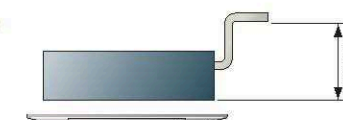

Comfortable air flow

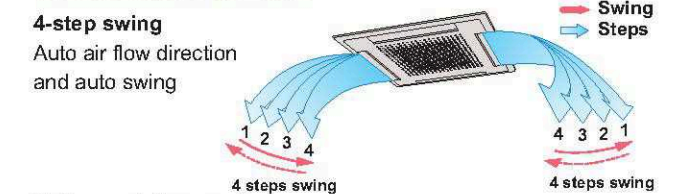

Wide air flow
Larger air flap distributes the outlet air flow a longer distance in the horizontal direction.

Duct connection hole opening

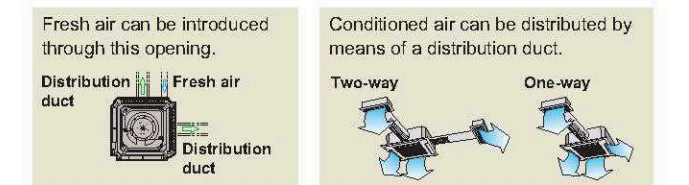

Improved noise level and air distribution

- Noise output has been dramatically lowered.
- Improved turbo fan shape (aerodynamic design)
- Expanded air distribution
- Low internal resistance
- Moulded fan motor

Air-flow volume can be switched

High ceiling mode (air flow up) and low-noise (air flow down) can be switched according to the height of the ceiling and other conditions by means of a PCB DIP switch.

	Standard	High 1 ceiling	High 2 ceiling	Low ceiling
Suitable ceiling height (m)	2.5—3	3—3.5	more than 3.5	less than 2.5

Draught prevention

Movement of the flap angle can be changed via a simple switch during installation, thereby preventing uncomfortable draughts.

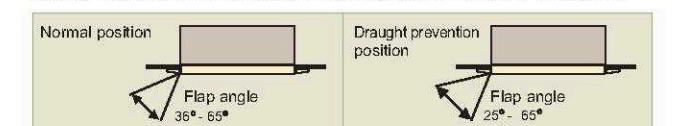

Cassette (Compact) / Cassette Type

flexible control

FLEXIBLE CONTROL SYSTEM



Compact design for easy installation and maintenance

Cassette Type (Compact)

Models

AU7 / AU9 / AU12 / AU14 / AU18

Features

Compact size

Compact grille fits European ceiling panel (600 x 600 mm).

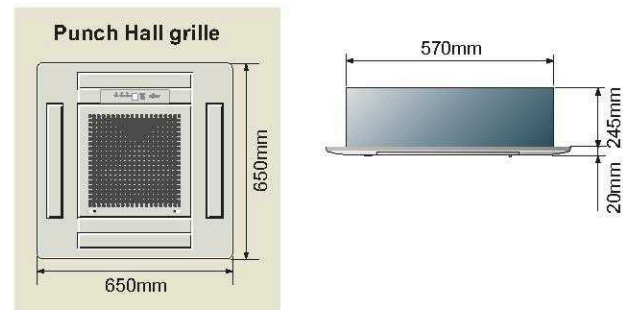

Comfortable air flow

4-step swing
Auto air flow direction and auto swing

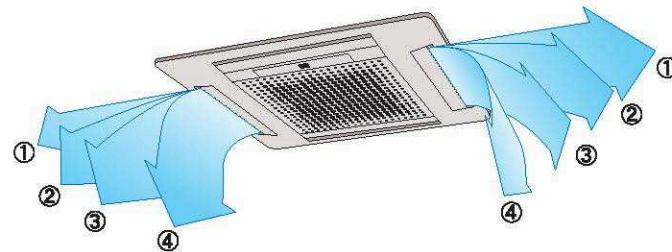

2-4 way air flow system
Select 2-way, 3-way or 4-way air flow to suit your needs.

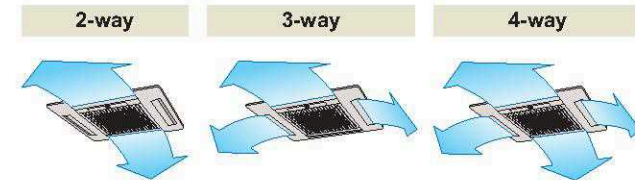

Easy maintenance

By placing the electrical component box inside the unit easy maintenance is assured.

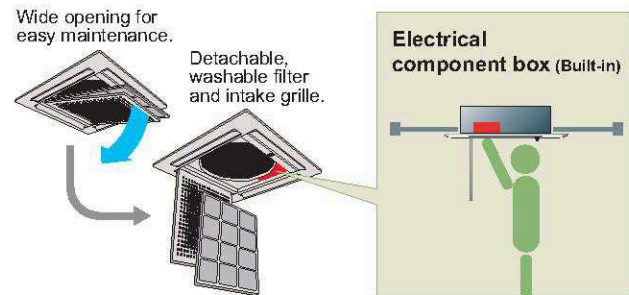

Condensate pump lift to 400mm



Low noise

Large air flow at reduced noise output achieved by incorporating a large diameter variable pitch turbo fan.

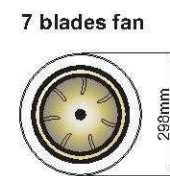

Draught prevention

Movement of the flap angle can be changed via a simple switch during installation, thereby preventing uncomfortable draughts.



Construction of Wiring System

Wiring configuration of the control system is made of power source wiring, transmission wiring and remote controller wiring.

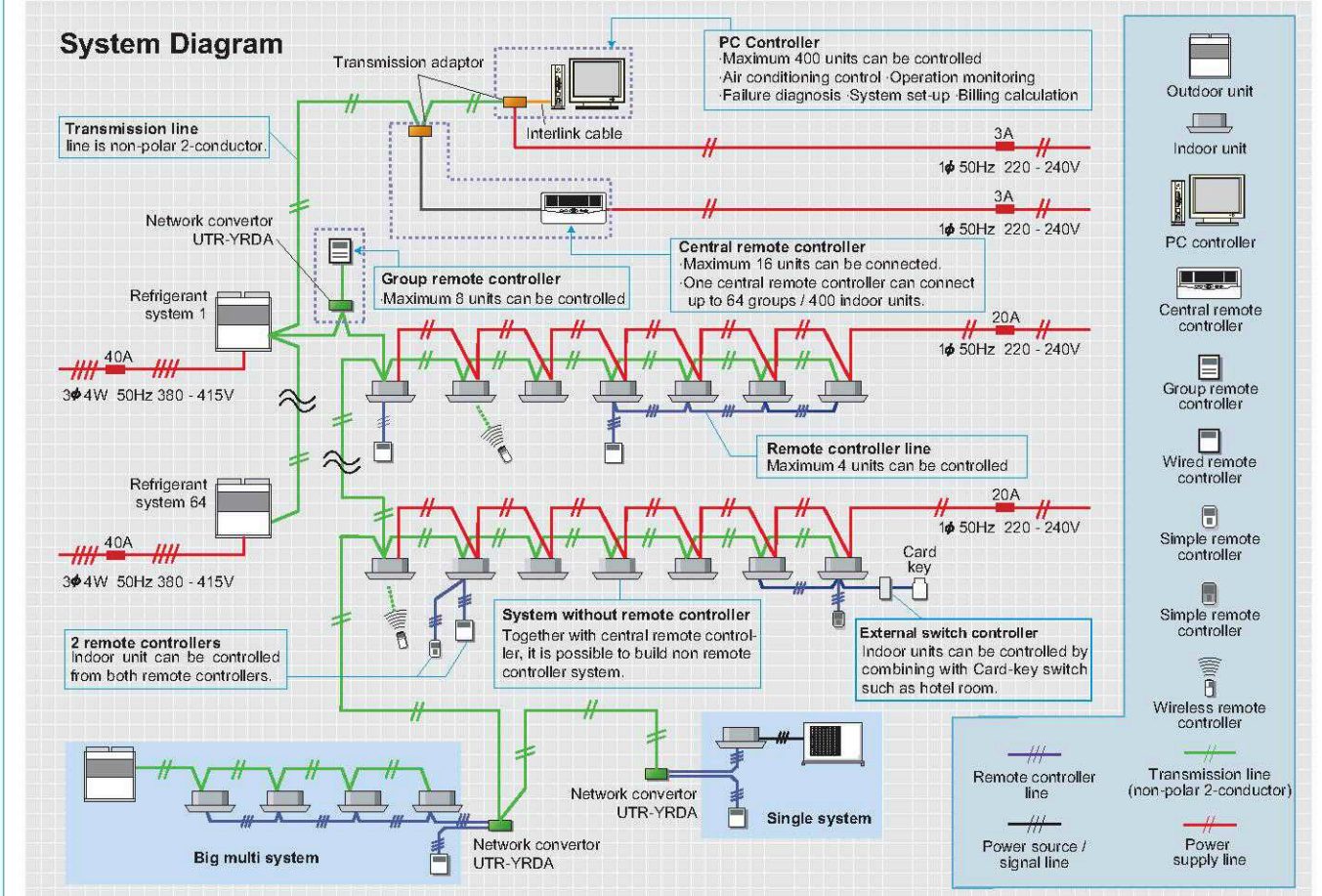

Maximum connectable number per one transmission line

Refrigerant system	100
Indoor units	400
Outdoor units	100

Combination of local remote controller

Wired, wireless and simple remote controllers can be used jointly.

Building Management System (BMS) Compatibility

It is possible to control not just the air conditioning system but the whole building management system including lighting and electrical facilities, hydraulic systems, fire alarm interface, security systems, etc.

Monitoring & Controlling for VRF system

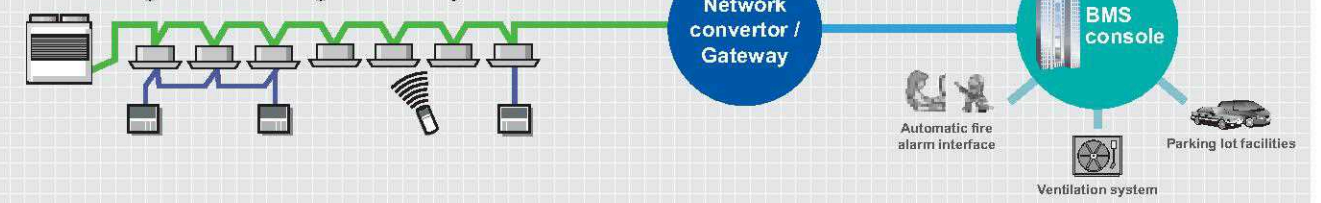

Controller features

Air conditioning central control

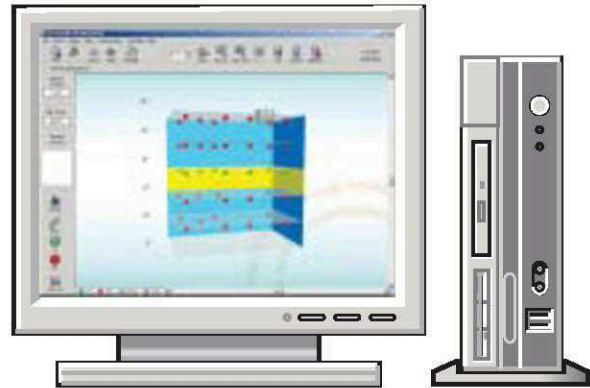

PC Controller [software] UTR-YOTB [Option]

High performance and optimum control system for various building applications

- Up to 400 indoor units/400 groups/64 remote controller groups can be connected into one system for large scale buildings or hotels.
- Provides powerful functions for building air conditioning management, including automatic calculations of electrical costs and numerous data management functions, as well as standard equipment monitoring and control.

Functions

Central building monitoring and control

- Detailed settings can be programmed for each whole building/group/remote controller group or individual indoor unit.
- The PC and central remote controller can be used together, allowing system control from two or more locations if required.

Central control

The 6 functions of the standard controller can be locked from the PC: all functions, timer mode, operating mode, temperature setting, filter reset, on/off. All functions can be controlled via the PC Controller only.

Auto mode (Priority-mode changer)

Auto mode function automatically switches between cooling and heating modes based on the temperatures set and the room temperature detected by the master indoor unit. Other operating indoor units can be operated in the same operating mode as the master indoor unit.

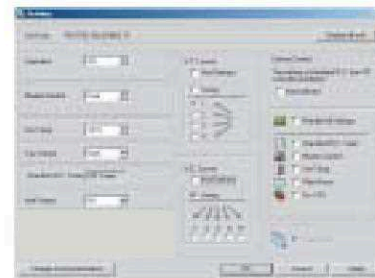

Operation Control

User-friendly Operation

- Runs under Windows®2000 and Windows®XP Professional / Home so is as easy to use as a standard PC.
- Operational status can be colour-coded for instant recognition: On/green, Off/red, test/orange, error/flashing.
- Operational status can be displayed to user's preference.

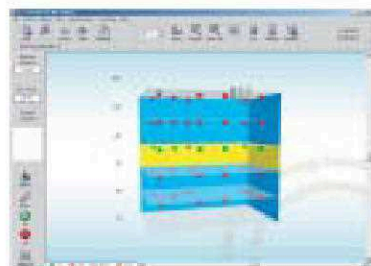



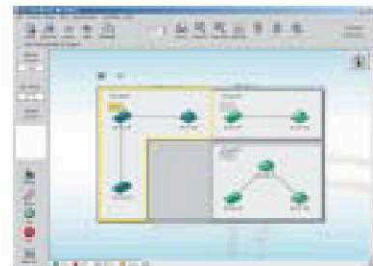

Rotating 3-D Display
When monitoring and controlling the operation by whole building.

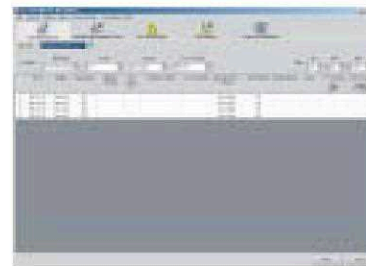

Floor Layout Display
When monitoring and controlling the operation by each floor or group.



List Table Display
When monitoring and controlling each unit in detail.

Floor & Ceiling Universal Type	Ceiling Type	Wall Mounted Type (Compact)	Wall Mounted Type	Ceiling Wall Type
 Model AB12 / AB14 / AB18 / AB24	 Model AB30 / AB36 / AB45 / AB54	 Model AS7 / AS9 / AS12 / AS14 • This indoor unit can't be operated in the Heat Recovery Type System.	 Model AS18 / AS24 / AS30	 Model AW7 / AW9 / AW12 / AW14 / AW18 / AW24 / AW30
see page 29	see page 30	see page 30	see page 31	see page 31
	●			
	●			
	●			
	●		●	●
●			●	●
●		●	●	●
●		●		●
●		●		●
		●		●
		●		●

Linking with external control equipment is possible.

Diverse air conditioning control systems linked with various equipment inside the building can be built by using the external I/O port.

Prevents wireless remote controller interference

The signal cord of the wireless remote controller can be switched and prevents erroneous operation by interference between adjacent indoor units.

Simple external appearance by auto shut flap

Gap-free, flat, and simple external appearance by closing of the flap when operation stops.

Symmetrical design

Left and right symmetrical design harmonizes with any interior design and creates a tranquil atmosphere.



Full Range of Indoor Units

A full and complete range of indoor units is available

Capacity (kW) (BTU/h)	Type	Cassette Type (Compact)	Cassette Type	Duct Type (Compact)	Duct Type	High Static Pressure Duct Type
	Model	Model	Model	Model	Model	Model
		AU7 / AU9 / AU12 / AU14 / AU18	AU20 / AU25 / AU30 (Slim Type) / AU36 / AU45 / AU54	AR7 / AR9 / AR12 / AR14 / AR18	AR25 / AR30 / AR36 / AR45	AR36(H) / AR45(H) / AR60(H)
		see page 26	see page 27	see page 28	see page 28	see page 29
17.00	60,000					●
14.10	54,000		●			
12.70	45,000		●		●	●
10.50	36,000		●		●	●
8.80	30,000		● Slim Type		●	
7.05	25,000		● Slim Type		●	
6.80	24,000					
5.70	20,000		● Slim Type			
5.30	18,000	●		●		
4.05	14,000	●		●		
3.60	12,000	●		●		
2.80	9,000	●		●		
2.15	7,000	●		●		

Common features

Room temperature feedback control

Comfortable temperature control can be achieved by feedback control of intake air temperatures and the opening of electronic expansion valve.

Room-temperature feedback control

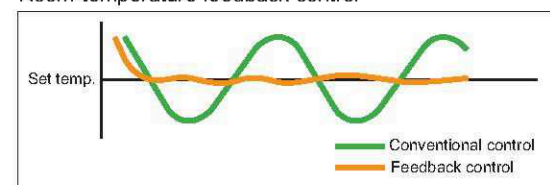

Energy saving operation

Energy saving operation is possible by changing the operation capacity according to the remote controller's setting.

COOLING operation :

The thermostat setting is automatically raised 1°C every 60 minutes, until the thermostat is raised a total of 2°C.

HEATING operation :

The thermostat setting is automatically lowered 1°C every 30 minutes, until the thermostat is lowered a total of 4°C.

Auto-Changeover

The unit automatically switches between heating and cooling modes based on your temperature setting and the room temperature.

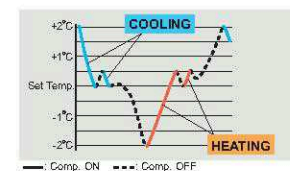

*It is only available for heat recovery type.

Calculating electrical costs

- Total electrical costs, billed for multiple indoor connected to the charge meter for air conditioning, is apportioned according to the accumulated refrigerant time and indoor unit capacity.
- Allows accounting for special rates (e.g., for night or weekend use).
- Calculations can be printed as final bills.

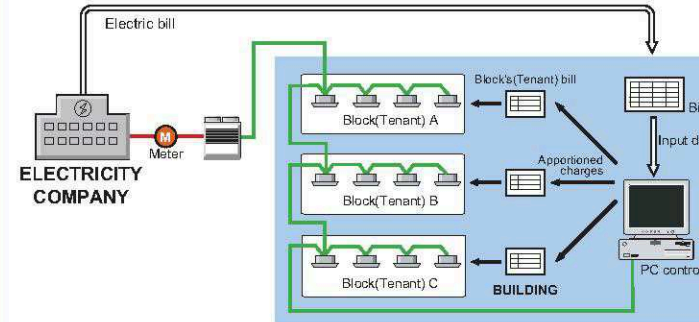

Schedule control

- Annual schedules can be set for each remote controller group.
- Start/stop, operating status, remote controller prohibition and temperature settings can be recorded up to 72 times per day at 10 minute intervals for up to 6 configurations for each remote controller group.
- Setting over midnight is possible.
- Holiday settings including public holidays for a complete year can be programmed.
- The 6 functions of the standard controller can be locked by schedule control.

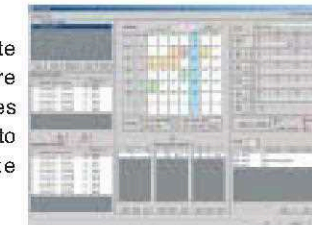

Error display

Audible alarms are accompanied with explanatory text. Up to 100 alarms can be recorded for each piece of equipment, particularly useful during maintenance.



Operating record

The operating status of indoor units and accumulated operating time of outdoor units can be recorded and a daily or monthly report produced.



Pattern setting

It enables to recognize operation status, such as ON/OFF, operation mode and set temperature, as a combination pattern. An arbitrarily pattern operation can be done with just one button clicking.

Easy Installation

- Simple connection by Transmission Adaptor and Interlink cable (Interlink cable field supplied).
- Simple installation of software using only the CD supplied.

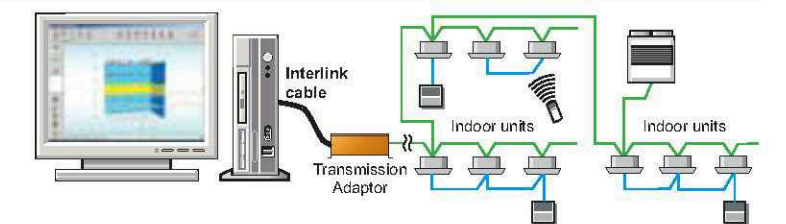

Requirements of PC for this software

Personal Computer	Operating System	AT compatible machine that runs Microsoft®Windows® Microsoft®Windows®2000 Professional (English version / Service pack3 or later) Microsoft®Windows®XP Professional / Home (English version / Service pack1 or later)
	CPU	Intel®Pentium®/ Celeron®, AMD Athlon™/ Duron™1GHz or higher
	HDD	4GB or more
	Memory	256 MB or more
	Interface	Serial port and USB port
Accelerator	Requires that the internal graphics accelerator be compatible with Microsoft®DirectX®7.0 or later	
Software	Adobe®Acrobat®Reader 4.0 or later	
Hardware	Interlink cable (D-sub 9pin female connector) (Parts No.: KRS-L09-4K) [Field supplied]	

<PACKING LIST>

Packing List	Software protection key / CD-ROM / Transmission Adaptor
--------------	---



Controller features

Air conditioning central control



Central Remote Controller

UTB-YCA / UTB-GCA [Option]

Functionality in a compact housing with built-in weekly timer

- Up to 400 indoor units/400 remote controller groups/64 groups can be controlled by one system.
- Up to 16 central remote controllers can be connected into one system allowing operation and monitoring to be achieved from the central control room, at each floor, by each tenant, or in the plant room.

Functions

Control up to 400 indoor units

- Central remote controller can control the system by selecting All Groups, User Defined Groups or Individual Remote Controller Groups
- Accurate control of functions such as Start/Stop, Operating Mode, Temperature, and Air Velocity ensures occupancy comfort.

Central control

The 6 functions of the standard remote controller can be locked from the Central Remote Controller: all functions, timer mode, operating mode, temperature setting, filter reset, on/off. All functions can be controlled via the Central Remote Controller only.

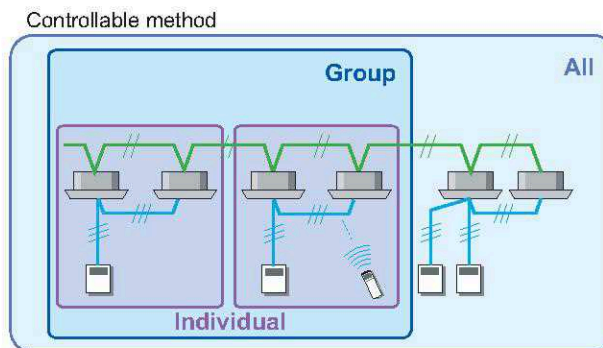

Easy Operation

- Control functions are divided into three clusters: Timer Control, Central Control and Operational Control, which are clearly displayed.
- A large liquid crystal display clearly indicates which indoor unit is currently in operation.

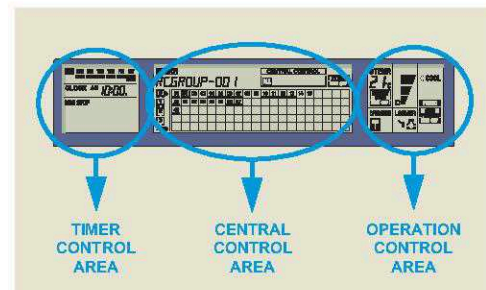
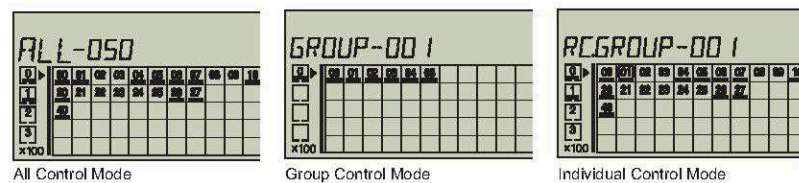

Simple Remote Controller

UTB-YPB / UTB-GPB / UTB-TPB [Option]
UTB-YRA / UTB-GRA / UTB-TRA [Option]

Simple remote controller concentrating on the basic operations.

- Up to 4 indoor units can be controlled with one remote controller.
- Suitable for hotels or offices which have many visitors coming in and going out and do not require detailed functions.



UTB-YPB / UTB-GPB / UTB-TPB, UTB-YRA / UTB-GRA / UTB-TRA

Dimension (H x W x D) (mm)	120 x 75 x 14
-----------------------------------	---------------

User friendly operation

- Concentrates on the basic operations such as On/Off, Fan Control, Operation Mode Switching, and Temperature Setting.
- A large Start/Stop button is provided in the centre of the remote controller unit for easy operation.
- Standard remote controller enable to use together.
- Diagnostics are carried out during the 'stop' mode following an error display.

Back ground light

- Backlight enables easy operation in a darkened room.
- The backlight is lit during the button operations, and also 10 seconds more in operation mode and 5 seconds more in stop mode.



Simple installation work

- Can be mounted on the European Mounting Box (Installation dimension: 60mm) or the JIS Built-in Box (Installation dimension: 83.5mm).

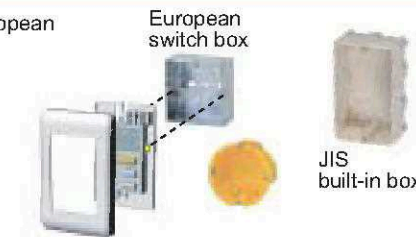

Functions

Model	UTB-YPB UTB-GPB UTB-TPB	UTB-YRA UTB-GRA UTB-TRA
Operation	●	●
On/Off	●	●
Fan control	●	●
Operation mode	●	—
Temp. setting	●	●

External Switch Controller

UTR-YESA [Option]

- ON/OFF, Temperature, Fan speed and Operation mode can be switched by a combination with Card-key switch equipped in facilities such as hotel room.
- Switching of air conditioner can be controlled by connecting other sensor switches.
- *Card-key and other sensor switches are available as a field supplied parts.

Dimension (H x W x D) (mm)	120 x 75 x 30
-----------------------------------	---------------

Electrical wiring

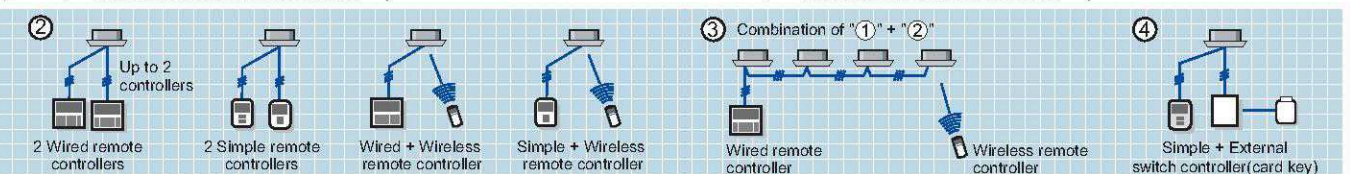
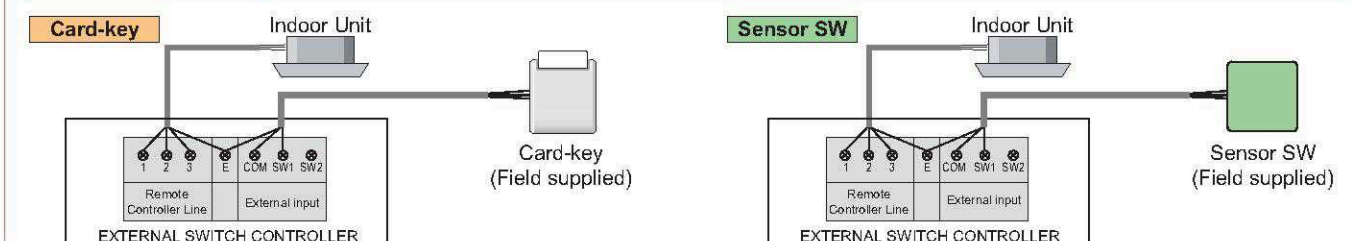



Controller features

Air conditioning individual control



UTB-YVB / UTB-GVB
Symbol type

Wireless Remote Controller

UTB-YVB / UTB-GVB [Option] Symbol type

Simple Operations with a Choice of 4 Daily Timers

Dimension (H x W x D) (mm)	158 x 56 x 20
-----------------------------------	---------------

Built-in daily timer

Select from 4 different timer programs : On / Off / Program / Sleep

Program Timer :

The program timer operates the ON and OFF timer once within a 24 hour period

Sleep Timer :

The sleep timer function automatically corrects the set temperature according to the time setting to prevent excessive cooling and heating while sleeping.

Cooling operation/dry operation

When the sleep timer is set, the set temperature automatically rises 1°C every hour. The set temperature can rise up to a maximum of 2°C.

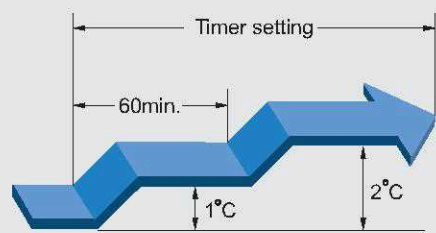

Heating operation

When the sleep timer is set, the set temperature automatically drops 1°C every 30 minutes. The set temperature can drop to a maximum of 4°C.

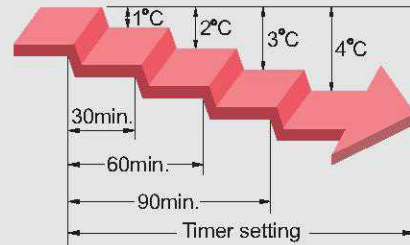

Easy installation and operation

• Code selector switch prevents indoor unit mix-up. (Up to 4 codes can be set.)

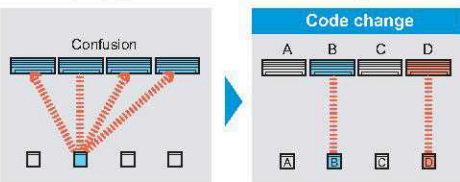

• Wide and precise transmitting range.

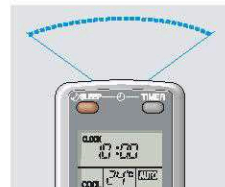

1. Press the MASTER CONTROL button for more than five seconds to start the code change.
2. Press the (+) or (-) button to select the desired code.
→ A → B → C → D
3. Press the MASTER CONTROL button again to end the code change.

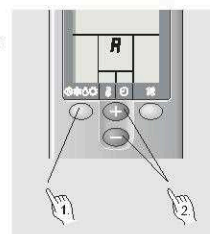

Standardization and simultaneous use of remote controllers

Wired, simple and wireless remote controllers can be used with the same indoor unit. Simultaneous use is also possible. A separate signal receiver kit is not required as the remote controller signal receiver is built into the indoor unit body.

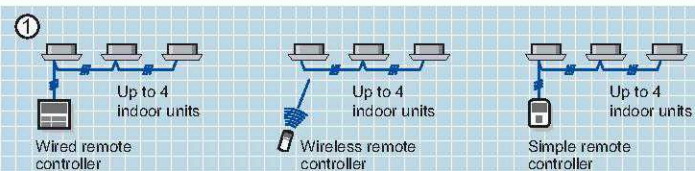

Built-in weekly timer

- The timer function, which can control up to 400 indoor units, provides detailed scheduling for each remote controller group.
- A simple approach to system configuration reduces wiring costs.

1. Possible to set different ON / OFF time twice a day for each day of the week.
2. Possible to set time in 10 minutes steps.
3. Time operation for a reserved day can be cancelled temporarily by pressing the "DAY OFF" button in advance.
4. Time setting can be carried over to the next day.
5. Copy and Paste can be used for time settings for each day.

Weekly schedule

Example : Office

On	---	■	■	■	■	■	---
Off	---	---	---	---	---	---	---
	Sun	Mon	Tue	Wed	Thu	Fri	Sat

Operation : Monday~Friday 8:00~12:00 and 13:00~18:00

Error display

Up to 62 error codes can be displayed. The last 2 error codes can be displayed, allowing easy inspection, service and maintenance.

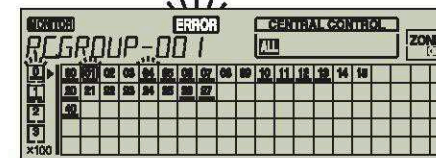

Advanced functions

Anti Freeze :

In cold regions, room temperature drops at night. This function prevents freezing of the water and other parts. When the room temperature drops to 5°C or less the heating is automatically switched on. Then the room temperature reaches 8°C the heating automatically switched off.

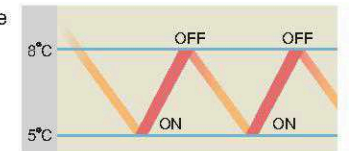

Energy Saving Operation :

During COOLING operation When the ENERGY SAVE is pressed, the thermostat setting is automatically raised 1°C every 60 minutes, until the thermostat is raised a total of 2°C.

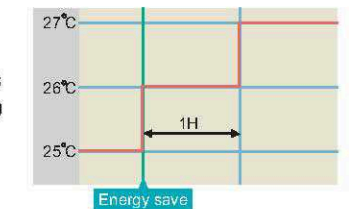

During HEATING operation When the ENERGY SAVE is pressed, the thermostat setting is automatically lowered 1°C every 30 minutes, until the thermostat is lowered a total of 4°C.

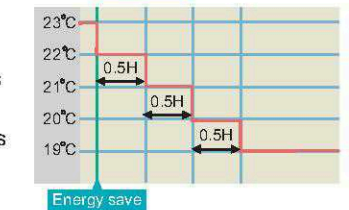

Memory : Central remote controller maintains original settings for indoor units. This data can easily be transmitted to the system even after the operating conditions have been changed.

Simple and Convenient Installation

- The controller can be installed on any flat surface.
- The control panel and transmission adaptor can be installed separately.
- For flexibility in installation, the main unit can be built into the wall or exposed.

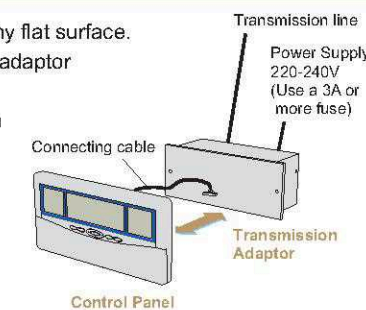

Setting Example (1)

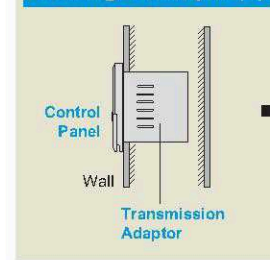

Setting Example (2)

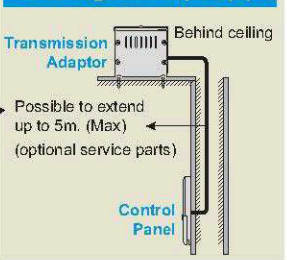

Specifications

	UTB-YCA / UTB-GCA	
	Control Panel	Transmission Adaptor
Power Supply	DC 12V	220-240V 50-60Hz Single phase
Power Consumption (W)	4.8	4.8
Fuse Capacity (A)	3	3
Dimension (H x W x D)(mm)	143 x 296 x 22	107 x 288 x 100
Weight (g)	550	1300
Packing Size (H x W x D)(mm)	---	145 x 330 x 190
Transmission Line	---	Shielded Non-polar, 2 core cable

<PACKING LIST>

Packing List	Control Panel / Transmission Adaptor / Connecting Cable
--------------	---



Controller features

Air conditioning central control



Group Remote Controller

UTB-YDB / UTB-GDB [Option]

Group control of indoor units with simple operation

- Up to 8 indoor units can be controlled by a single controller.
- Up to 64 Group Remote Controllers can be connected in a single VRF system.
- Network Converter (UTR-YRDA) is required to connect Group Remote Controllers to a VRF system.

Controller features

Air conditioning individual control

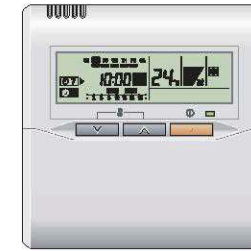

Wired Remote Controller

UTB-YUB / UTB-GUB / UTB-TUB [Option]

Simple Operation with Built-in Weekly / Daily Timer

- Up to 4 indoor units can be controlled with 1 controller.
- Up to 2 wired remote controllers can be connected to 1 indoor unit.

Dimension (H x W x D) (mm)	120 x 120 x 17
----------------------------	----------------

- Build-in thermo sensor doesn't work in S series system.

Control up to 8 indoor units

- Control and monitoring of up to 8 indoor units is possible with a single Group Remote Controller.
- Up to 64 Group Remote Controllers can be connected in a single VRF system.
- 4 Group Remote Controllers can be connected to a single Network Converter (UTR-YRDA).
- A single Network Converter (UTR-YRDA) covers 2 refrigerant circuits.

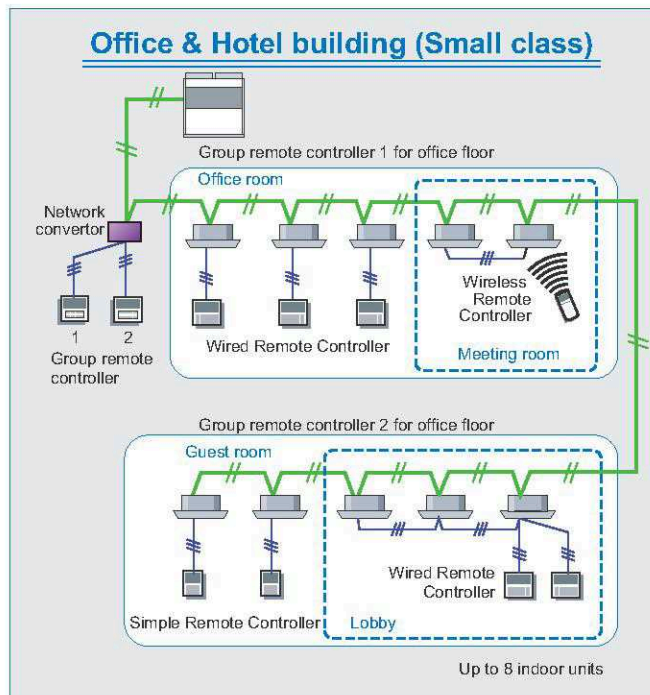

High performance and compact size

- ON/OFF, operation mode, set temperature and air flow can be controlled / monitored centrally or individually.

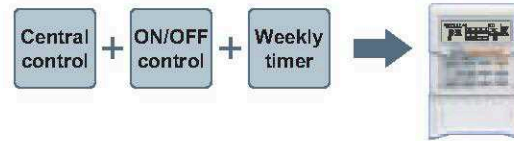

Built-in weekly timers

The WEEKLY TIMER is provided as a standard function.

1. The timer can be set up for up to 4 times/day. (On/Off, operating mode, set temperature)
2. Allows separate settings for each day of the week.

ON/OFF switching

Cooling/Heating switching

Temperature switching (Peak cut)

Temperature switching (Anti-freeze)

Stop setting

Powerful features and compact size

This wired remote controller incorporates three primary functions into a single unit.

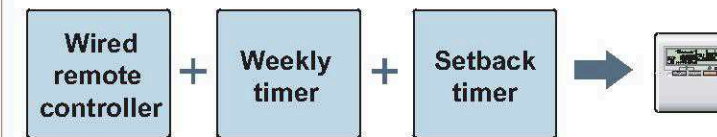

Easy-to-understand operation

Diverse timer control

The operation / display section are zoned into a timer area and an operation area. Also, the ON/OFF timer uses a remaining time feature and allows diverse timer settings corresponding to the application.

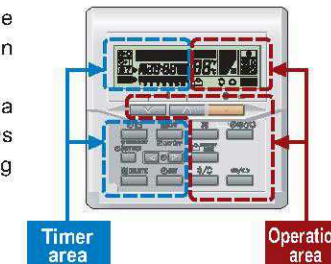

Built-in timers

Weekly timer :

Two ON/OFF times can be set for each day of the week.

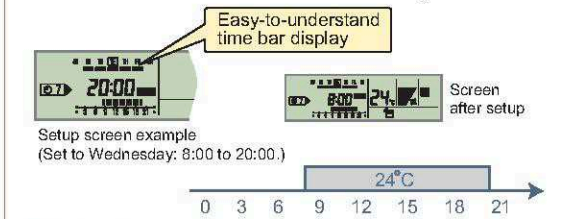

Setback timer :

Allows the user to set temperatures for two time spans over the course of each day of the week.



At "Weekly timer" + "Set back timer" setup :

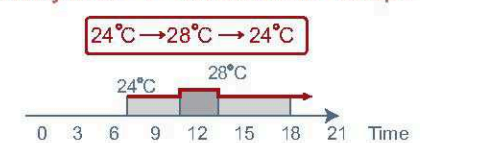

Energy Saving Operation

Energy saving operation is possible by changing the operation capacity according to the remote controller's setting. (See details on page 24)

Simple installation work

Can be mounted on the European Mounting Box (Installation dimension: 60mm) or the JIS Built-in Box (Installation dimension: 83.5mm).

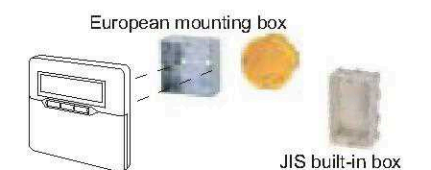

Specifications

Model	Group Remote Controller		Network Converter	
	UTB-YDB / UTB-GDB		UTR-YRDA [Option]	
Power Supply	DC 12V		220-240V 50-60Hz	
Dimension (mm)	Height	120	67	
	Width	120	288	
	Depth	17	211	
Weight (g)	160		1,400	

Diagnosis check function

There are two methods for interrogating the cause of failure when a malfunction occurs:

Malfunction diagnosis function :

Should an abnormality occur during system operation, the error code of the connected indoor units can be displayed.

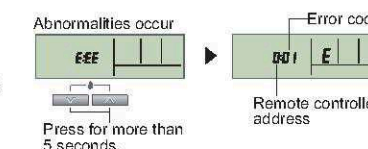

Error history :

The last 16 error codes can be accessed via the controller. This is useful for troubleshooting system abnormalities and helpful for determining error causes.

